



Flex Cam[®]

Volvo standard

Kaller is the Volvo Cars standard for gas springs, hydraulic cams and roller cams. In the downloads here you find the Volvo Cars part numbers for all Kaller parts that are Volvo Cars standard.

- **GREEN**: Preference 1. The items that are "first choice" have the Volvo Cars part numbers marked green.
- **YELLOW**: Preference 2. The items with yellow Volvo Cars part numbers can be used if the green marked alternative is impossible to use in the specific case.
- **UNCOLOURED**: The items with uncoloured Volvo Cars part numbers must not be used for new design, only for replacement in old dies.

Items that are not provided with Volvo Cars part numbers can be used after confirmation from Volvo Cars: please contact your technical contact person at Volvo Cars.

CONTENTS - *Flex Cam*[®]

Introduction	9.1/1
Component description	9.2/1
Power Unit (HCP and (HCP-S)	9.2/1
Compact Cam (CC and CCH)	9.2/2
Flange Cam (CCF and CCF-H)	9.2/3
Force Cylinder (HCF)	9.2/4
Function description	9.3/1
Normal use	9.3/1
Safety function	9.3/2
Pressure build up in the system	9.3/2
Connection of two or more Cam Units to one Power Unit.....	9.3/2
Parallel movement with two systems	9.3/3
Adapting the Cam stroke ratios.....	9.3/3
Installation examples	9.4/1
Application example using Compact Cam	9.4/1
Application example using Force Cylinder	9.4/1
Installations currently in operation	9.4/2
Advantages and possibilities of using Flex Cam	9.5/1

CONTENTS - *Flex Cam*[®]

Component selection	9.6/1
Technical data.....	9.7/1
Capacity and performance.....	9.7/1
Other specifications	9.7/1
Cam Unit/ Force Cylinder as a function of nitrogen pressure in the Accumulator..	9.7/2
Dimensions for Power and Cam Units/ Force Cylinders.....	9.8/1
Size 015 (15 kN)	9.8/1
HCP, HCP-S, CC, CC-H, HCF, HCF-SP.....	
Size 040 (40 kN)	9.8/7
HCP, HCP-S, CC, CC-H, CCF, CCF-H, HCF, HCF-SP.....	
Size 060 (60 kN)	9.8/17
HCP, HCP-S, CC, CC-H, HCF, HCF-SP.....	
Size 090 (90 kN)	9.8/23
HCP, HCP-S, CC, CC-H, HCF, HCF-SP.....	
Size 150 (150 kN)	9.8/29
HCP, HCP-S, CC, CC-H, HCF, HCF-SP.....	
Dimensions for accessories.....	9.8/35
Sensor kit, option for Compact Cam, CC and CC-H.....	9.8/35
Security Block, according to CNOMO-Standard	9.8/36
System hoses	9.8/37
Manifold Block for Flex Cam	9.8/46
System adapters.....	9.8/47
Designing your hose system.....	9.8/48
Hose systems for control units and oil bleeding.....	9.8/50
Pump Unit	9.8/54
EHC Electrical Pump Unit.....	9.8/55

CONTENTS - *Flex Cam*[®]

Installation and Service	9.9/1
Guidelines	9.9/1
Installation	9.10/1
Power Unit	9.10/1
Compact Cam	9.10/1
Flange Cam installation possibilities	9.10/2
Flange Cam force direction and location.....	9.10/2
Force Cylinder.....	9.10/3
Hydraulic hoses and adapters	9.10/3
Filling of gas and oil	9.11/1
Gas charging for Cam Unit/ Force Cylinder and Accumulator	9.11/1
Oil filling and bleeding	9.11/2
Changing the oil.....	9.11/5
Service and maintenance	9.12/1
Power Unit and Force Cylinder (HCP, HCP-S, HCF).....	9.12/1
Compact Cam (CC)/ Flange Cam (CCF)	9.12/1
Compact Cam (CC-H)/ Flange Cam (CCF-H)	9.12/2
Oil	9.12/3
Pump Unit	9.12/3
Fault diagnosis and solutions.....	9.12/4

Introduction

The Flex Cam can be used for piercing, cutting, forming and flanging operations.

The system allows for a flexible distribution of forces with optimal direction and velocity during the operation. Cam Units or Force Cylinders can be coupled together to allow for multiple operations within the same tool to be performed simultaneously. Often by using a Flex Cam, fewer tools are required to produce the part.

The system comprises of a Hydraulic Power Unit, Cam Unit/Force Cylinder and interconnecting hoses. Different types of Cam Units/Force Cylinders are available to suit various types of applications. For technical data and dimensions refer to page 9.7/1 and 9.8/1.

For further information contact your local distributor or Strömsholmen AB at www.kaller.com or Phone: +46 140-571 00 and Fax: +46 140-571 98.

Component description

Power Unit (HCP)

The Power Unit consists of an Accumulator (1), Power Cylinder (2) and a base plate (3). The purpose of the Accumulator is to set the force of the Cam and to prevent overpressurisation of the system. It will also contain some oil once the Cam has reached its stop position.

When the piston of the Power Cylinder is struck by the press (or machine) the Cam Units will then be actuated.

The size of the Power Unit is calculated from the number of Cam Units in the system, their sizes and their length of stroke.

Note that the piston (4) of the Power Cylinder is at the same height as the Accumulator when this system is completely filled with oil.

The strokes specified are -0350, -0600, -1100 and 1600 in the order numbers. 10 mm extra stroke for the Accumulator is included.

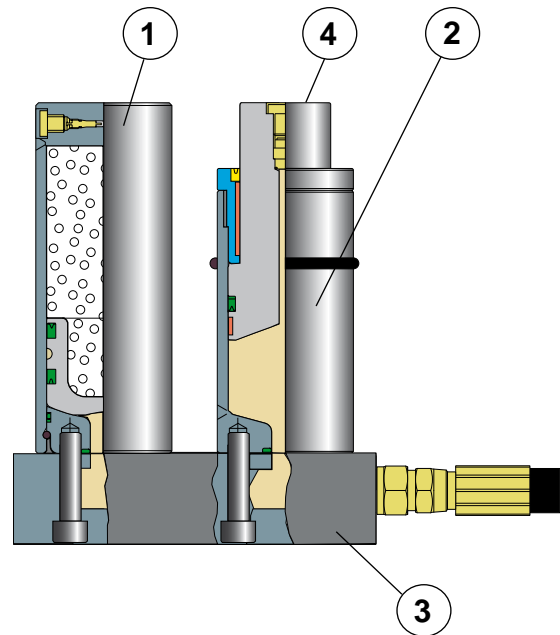

Power Unit (HCP-S)

Where there are space restrictions within the tool, then the Power Unit is also available with separated Power Cylinder and Accumulator. See section 9.8 "Dimensions for Power and Cam Units".

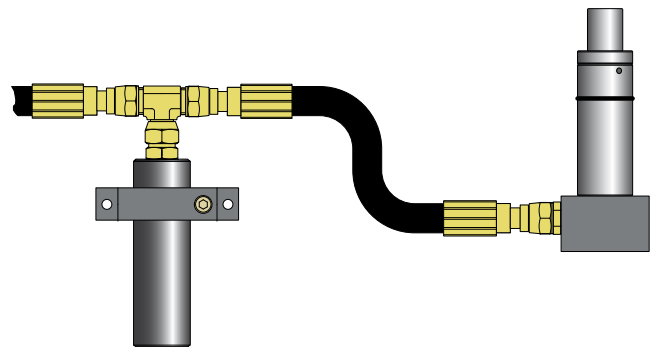

Mounting orientation

Both HCP and HCP-S Power Units can be mounted at any angle and orientation which best fits the tool.

Alternative driver

It is also possible to use an electrically powered Hydraulic Pump Unit (EHC) as a driver for the Cam Units. See page 9.8/45.

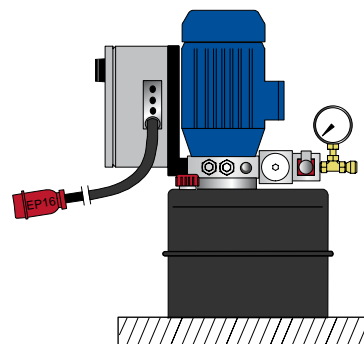

Compact Cam (CC)

The Compact Cam is a well guided unit, suitable for normal piercing operations with or without a small amount of side loading.

It consists of a piston with a piston rod (1), guide (2), sleeve (3), front housing (4), rear housing (5), bleed nipple (6), gas spring (7), anti rotation rods (8) and a punch adapter plate (9) for the punch holder.

The Power Unit (HCP) or Hydraulic Pump Unit (EHC) can be used to actuate the Compact Cam. The Cam return force is provided by one or two internally installed gas springs. The punch adapter plate is prevented from rotating by the two anti-rotation rods.

The use of a polyurethane stripper is recommended in piercing or cutting operations to hold the panel down and to strip the punch from the panel.

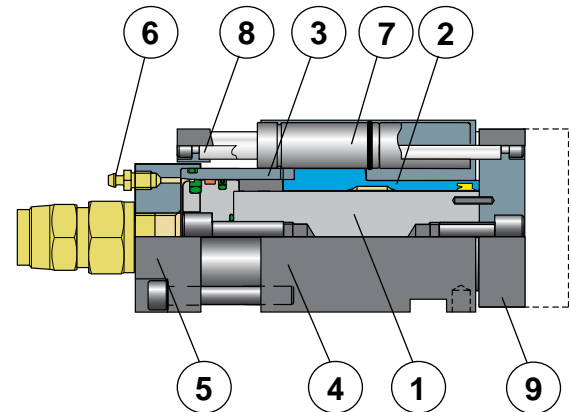

2

Compact Cam (CC-H) for Hose System

The Compact Cam is also available in a version where the gas springs in the unit can be hoses to a control armature. This way the gas pressure in the spring can be monitored from outside the tool. See section 9.8 "Dimensions for Power and Cam Units/ Force Cylinders".

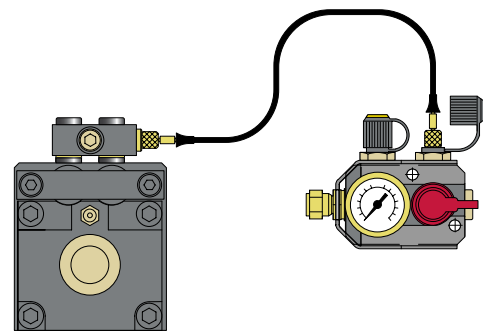

Option for CC and CC-H

A complete kit with proximity sensors (1), fittings, screws etc. can be fitted to the Compact Cams so that extended and retracted positions can be monitored.

See section 9.8 "Dimensions for Power and Cam Units/ Force Cylinders".

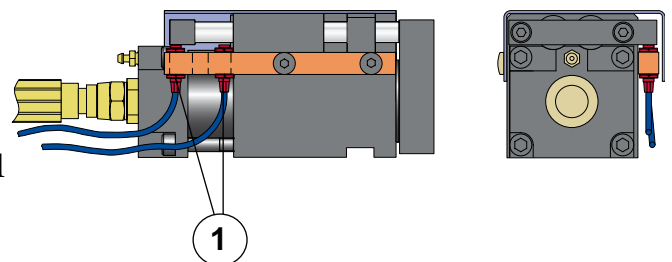

Flange Cam (CCF)

Patent No. SE 513031,
EP 1212156

The Flange Cam is suitable for flanging and other operations with large amounts of side load.

No extra guides are required as the front adapter plate (1) is equipped with two roller bearings (2).

A Compact Cam Unit (3) is used as the driver and a bottom plate (4) provides support for the front adapter plate.

The Power Unit will actuate the Flange Cam and the return movement is provided by two internally installed gas springs.

The front adapter plate is prepared with threaded holes to mount any customised flanging tool etc.

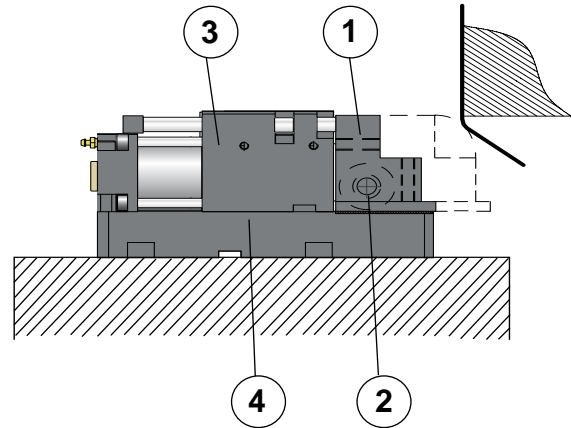

Patent No. SE 513031, EP 1212156

Flange Cam (CCF - H) for Hose System

The Flange Cam is also available in a version where the gas springs in the unit can be hoses to a control armature. This way the gas pressure in the spring can be monitored from outside the tool.

See section 9.8 "Dimensions for Power and Cam Units/ Force Cylinders".

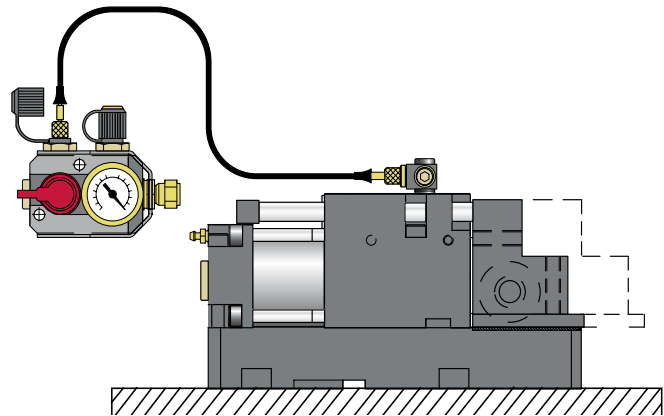

Flange Cam spacers (optional)

The spacers (1) are required when mounting the Flange Cam from above (top mount) as shown here.

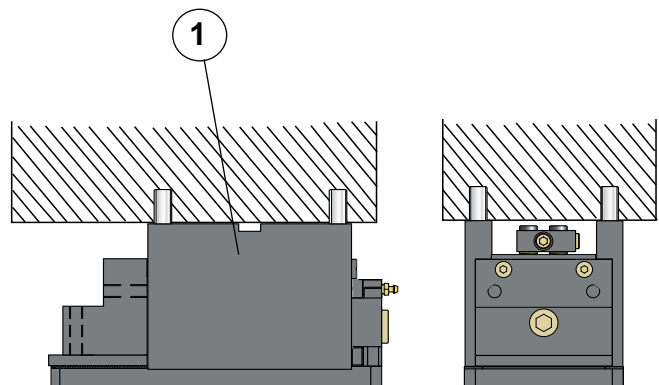

Force Cylinder (HCF)

The Force Cylinder is suitable for forward and return motion of, for example, a flanging steel or forming punch used for various operations in the tool. Note that it is not possible to mount a punch directly onto the piston rod without a guide in the tool.

The Force Cylinder consists of a cylinder (1), piston with a piston rod (2), guide (3), gas valve (4), gas for return (5) and a bleed nipple (6).

The Power Unit (HCP) or Electrical Pump Unit (EHC) can be used to actuate the Force Cylinder. The return force is provided by the internal nitrogen pressure within the Force Cylinder. The Force Cylinder can be mounted using different types of flanges.

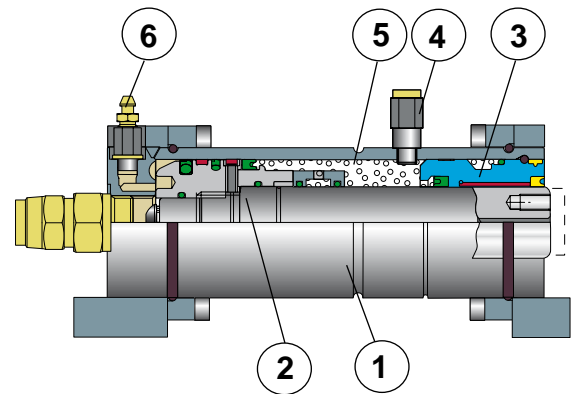

Function description

Normal use

The illustration below shows the Power Unit (HCP) and the Compact Cam (CC). The system works identically for a Compact Cam (CC), Flange Cam (CCF) or a Force Cylinder (HCF).

Before the press (or machine) activates the Power Unit the oil pressure is 0 bar but the Accumulator and the return Gas Springs in the Cam (or Force Cylinder) are charged with nitrogen (1). When the press strikes the piston in the Power Unit (2), the Cam will be actuated and the operation will thus be carried out.

When the press returns upwards the movable parts will return to their original positions due to the return Gas Springs in the Cam (or nitrogen pressure in the Force Cylinder) and Accumulator.

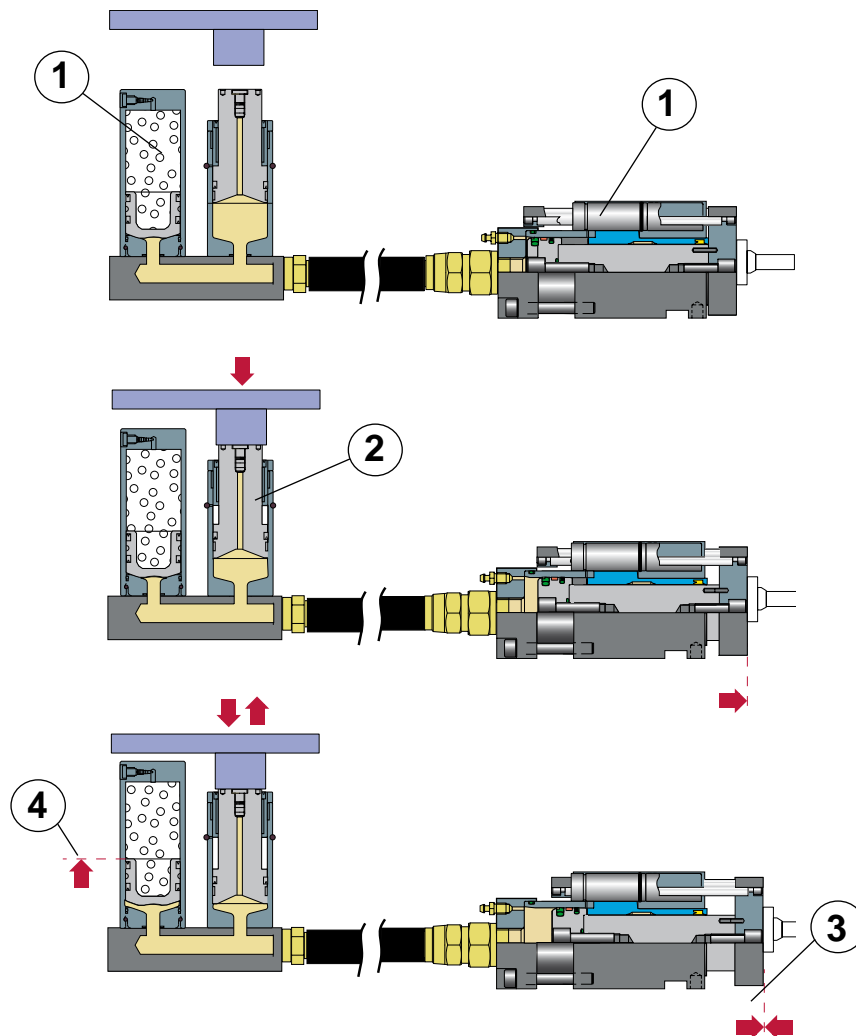

Safety function

If the movement of the Cam is restricted in the tool (1), the piston in the Accumulator will be raised instead (2). The oil moves into the Accumulator to prevent over pressurisation of the system.

When the restriction has been removed the unit will function normally without needing to be refilled with oil.

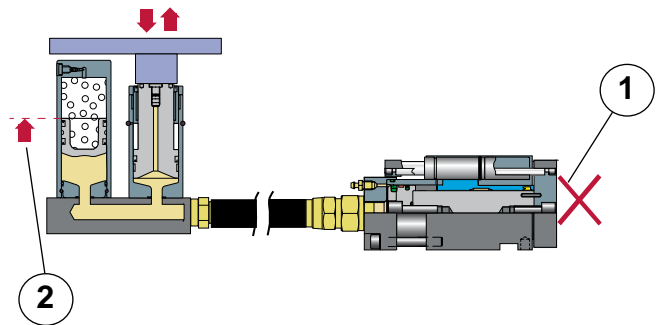

Pressure build up in the system

Before the Power Unit is activated the oil pressure is 0 bar (1).

The force from the gas pressure in the Cam Unit causes the oil pressure to increase (2).

The oil pressure will increase to create enough force needed to perform the operation (3).

When the Cam reaches its stop position the oil pressure increases to lift the piston in the Accumulator with a force equal to the nitrogen pressure (4) within the Accumulator.

If the movement of the Cam is restricted the oil pressure will follow curve (5).

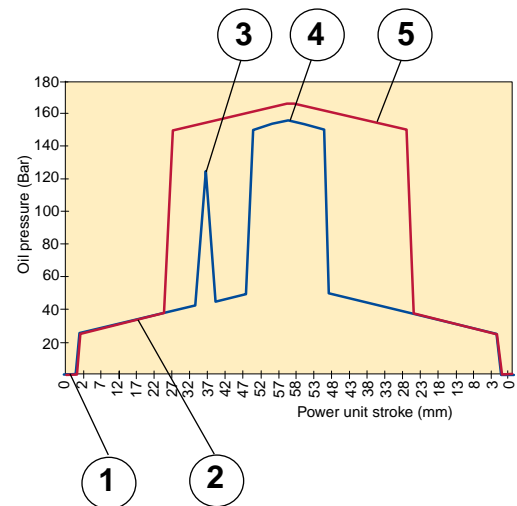

Connection of two or more Cam Units to one Power Unit

It is possible to connect up to three Cam Units to one Power Unit. Note that the movement of the Cams during the stroke are not synchronised (1) until the Cams are in the fully extended position (2).

If more than three Cams are connected to one Power Unit the velocity in some of the Cams could be too high. The system could also be difficult to bleed and therefore is not recommended.

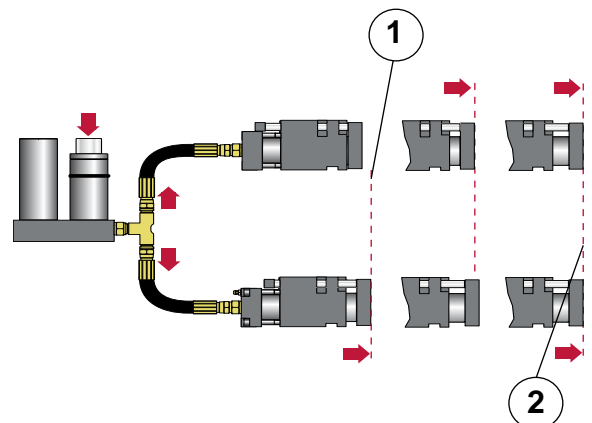

Parallel movement with two systems

For parallel movements where different forces may be required, it is recommended that two separate systems are used. For example, in order to move large pads in tools.

Here the movement of each Force Cylinder is synchronised regardless of the individual force required by each Force Cylinder.

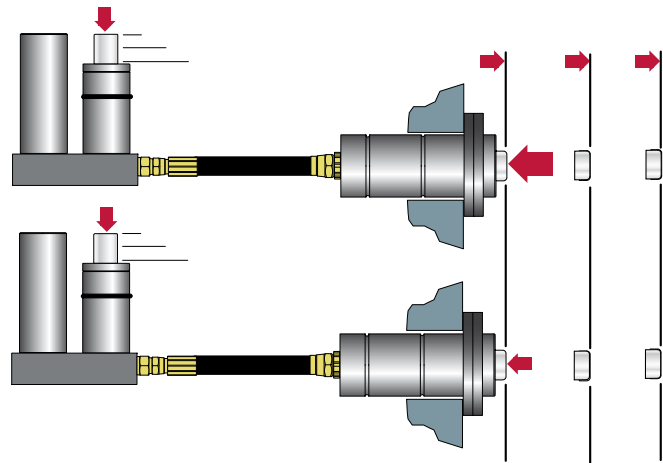

Adapting Cam stroke ratios

If you use a large Power Unit (eg. HCP 040) connected to a small Cam Unit (eg. CC 015) the stroke of the Cam Unit will increase in relation to the stroke of the press.

The difference in strokes is related to the stroke difference in piston areas. The stroke of the Cam Units will be faster than the stroke of the press (1).

$$(S_{\text{Press}} < S_{\text{Cam Unit}})$$

The opposite is also possible, shorter stroke of the Cam in relation to the press stroke (2).

$$(S_{\text{Press}} > S_{\text{Cam Unit}})$$

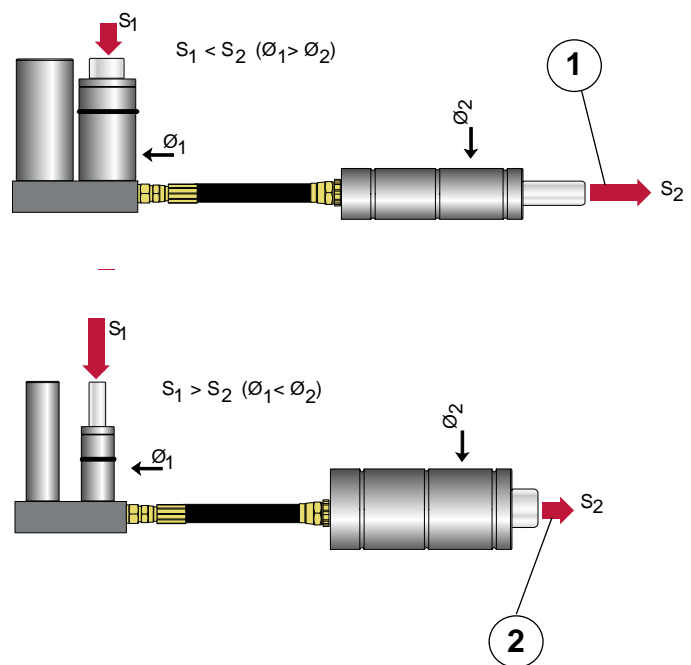

It is important that the velocity of the Cam does not exceed the specifications on page 9.7/1 "Technical data" See also page 9.6/4 "Component selection" step 5.

Installation examples

Application example using the Compact Cam

This example shows how a Compact Cam (1) can be used for piercing. The punch can be attached directly to the Cam Unit and no additional guides are required in the tool. As seen in the picture, the Power Unit can be placed remotely from the Cam Unit. This gives increased flexibility compared to a conventional mechanical solution. A stripper (2) on the punch is recommended.

Work cycle

As the upper tool moves downwards the blank holder (3) is activated and will keep the blank in position. The blank holder is guided relative to the lower die using V-blocks.

When the blank holder is in position the Power Unit (4) will be activated and the Cam Unit will perform the punch operation.

Note that the Power Unit can be mounted at any location and orientation to the Cam Unit/Force Cylinder and not just as is depicted in these examples.

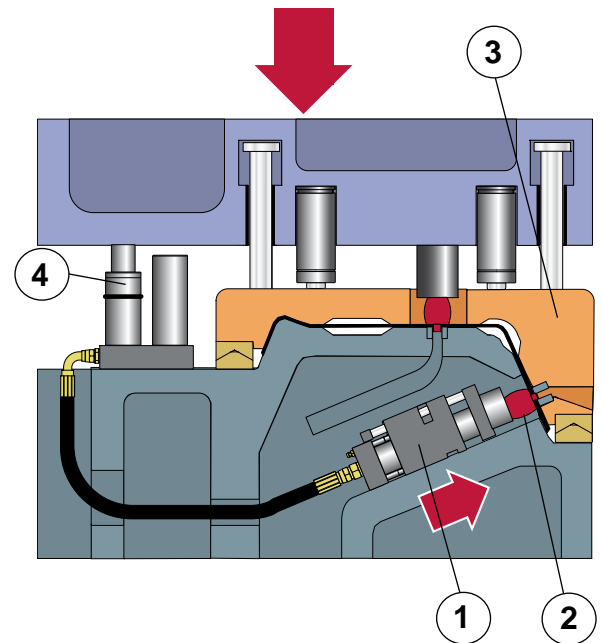

Application example using the Force Cylinder

This example shows how one or more Force Cylinders (1) can be used to drive forming punches (2) (or cam slides) in a tool. The punch (or slide) is guided in the tool. This method of driving tool 'components' allows for high flexibility in tool design. The Force Cylinder supplies the motion and force. Only pulling and pushing forces are possible.

Work cycle

As the upper tool moves downwards the blank holder is activated and will keep the blank in position. When the blank holder is in position the Power Unit (3) is activated thus activating the Force Cylinder.

The forming force can be adjusted by simply changing the pressure in the Accumulator (4).

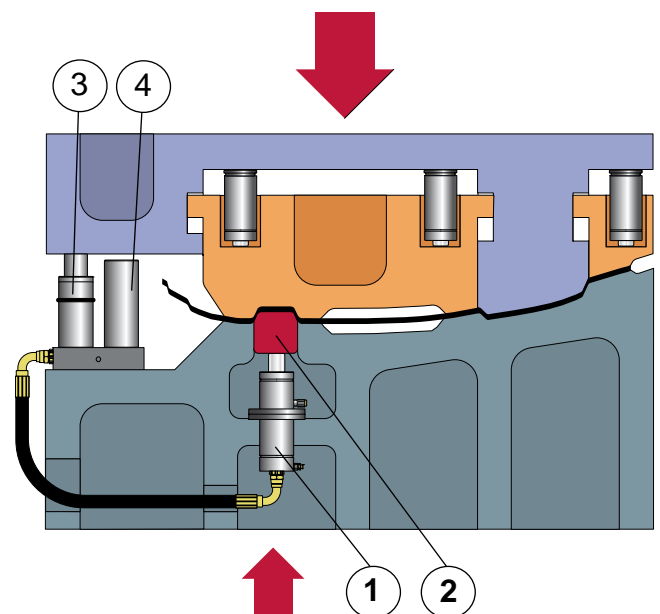

Installations currently in operation

The following examples are of installations now running in production and illustrates some of the different ways the benefits of the Flex Cam are being used.

Example 1, Piercing 4 x 3 holes

12 holes are being pierced at an undercut angle (1). In this tool a mechanically driven pad (2) has been equipped with Flex Cams.

During the first part of the operation the pad is moved into position, using the angled part of the drivers (3). Once the pad is in position, the drivers become inoperative by only sliding on their vertical faces. The Power Units are activated and the holes are punched by the Cams (4).

Using this solution there is no longer the need for drivers at the punching position and therefore punching operations can easily be carried out perpendicularly to the blank.

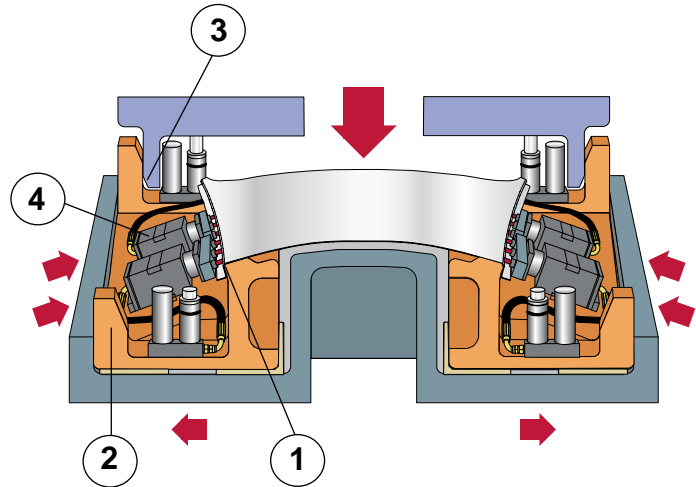

Example 2, Piercing 2 x 3 holes

6 holes are being punched at an undercut angle using Force Cylinders activating a pivoting piercing unit (1).

The picture shows the unit in its extended position (press at bottom dead centre). As the Force Cylinder (2) starts to move backwards, the punch retracts from the hole and thereafter the whole unit will pivot down allowing for the part to be removed. The reverse will happen as the press moves back down.

There are two systems in the tool, one on the left side, one on the right. Each system consists of one Power Unit (3) driving three Force Cylinders.

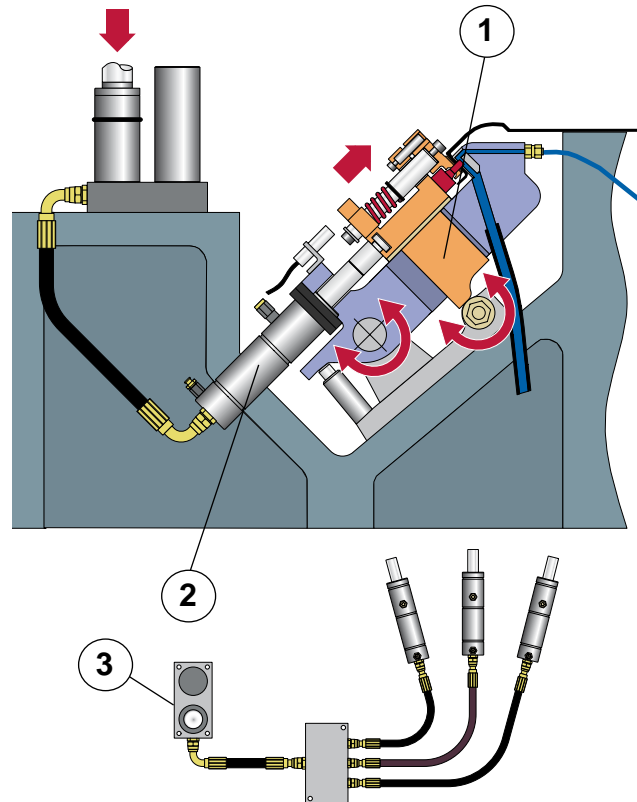

Example 3, Piercing 2 holes in two parts

In this tool two parts are being produced simultaneously. The left part of the picture shows the press at its upper position. The right part shows the press in its bottom position. Shown above the Cam Units are the transfer arms.

To allow the flange of the part to pass the punches, before the Cam Units are activated, a smaller size Cam Unit has been connected to a bigger size Power Unit. In this case a 1.5 tonne Cam 015 (1) connected to a 4 tonne Power Unit HCP 040 (2). This will give a stroke ratio of 2.5. (As the press/Power Unit moves 10 mm vertically, the Cam Unit will move 25 mm horizontally)

Two versions of the same part are produced, one with holes and one without. For the part without holes, the Power Unit is simply removed from the tool, thus disabling the Cam Units from making the holes.

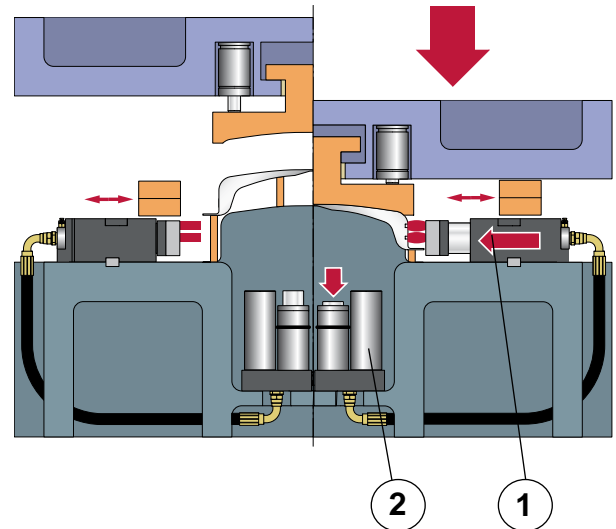

Example 4, Piercing 6 holes

This application uses an hydraulic cam system mounted upside down in the upper tool. The Cam Unit (1) is mounted on a floating die (2). The floating die is centred relative to the lower die using conical pillars and the die is backed up by springs. As the press moves downwards, and the floating die is centred, the Power Unit (3) is activated and the holes are punched.

Prior to the installation of the hydraulic cam system, the holes were being punched at a vertical angle using oval shaped punches.

The production and quality enhancements, as a result of the installation of the Flex Cam, resulted in a payback time of three months for the system, including installation.

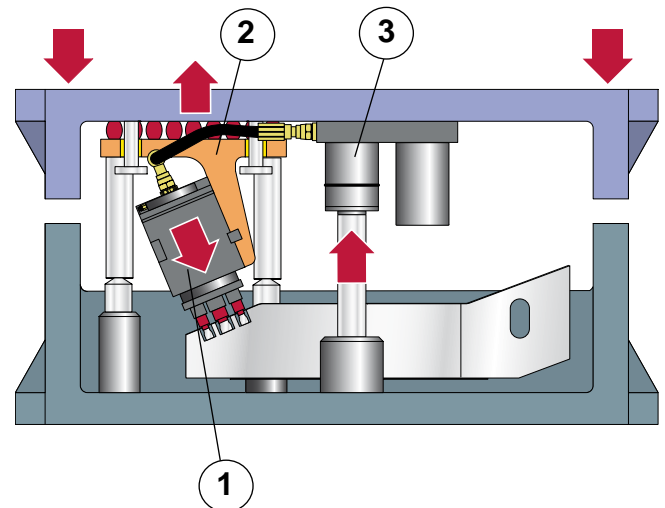

Example 5, Flanging

The picture shows a floor panel where Flange Cam Units (1) are being used for flanging upwards (2). All side loading forces associated with the flanging operation are taken up within the Flange Cam Units.

In this case the customer saves the cost of one complete tool, by using the Flex Cam, as these operations could be added to an existing tool. The other option would have been to produce a completely new tool with a floating pad.

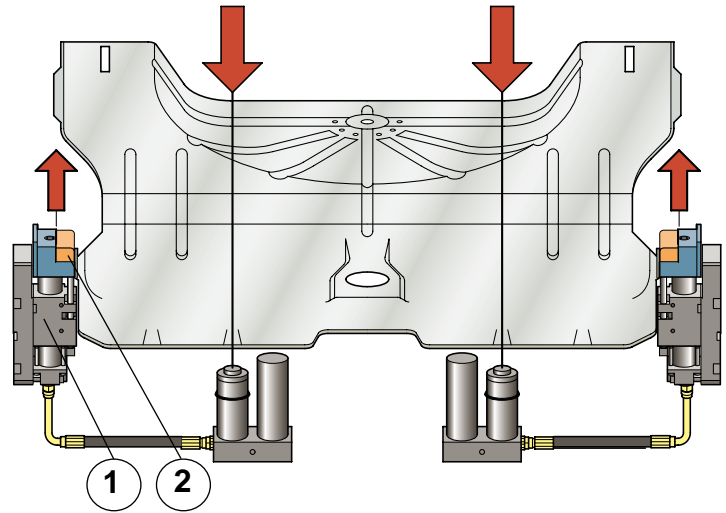

Example 6, Flanging a wide edge

In this tool two Force Cylinders are being used to drive a 800 mm wide flanging steel. As seen in the picture the flanging (1) is carried out at an angle opposite to the direction of the press motion.

To ensure a parallel movement at both ends of the flanging steel two separate cam systems are being used. Each system containing a Power Unit (2) and a Force Cylinder (3).

The flanging steel (4) is well guided in the tool and the Force Cylinders are only subject to axial forces.

Using the Flex Cam has simplified the design of the tool and therefore also reduced the tooling cost.

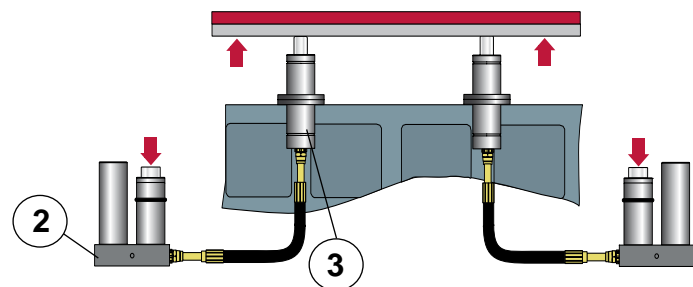
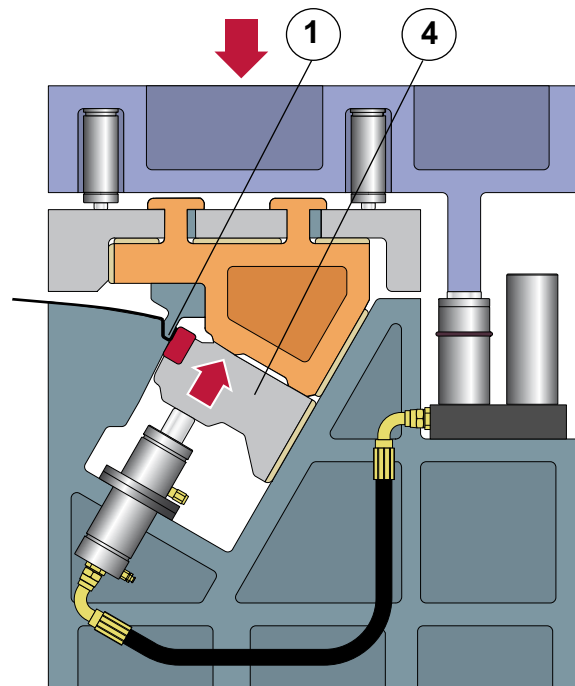

Advantages and possibilities of using Flex Cam

1. The number of tools required to produce a part can be reduced since flanging and piercing operations can now easily be performed within the same tool
2. The cost of the tool could be reduced due to a more simplified tool design
3. The system “drivers” do not have to be positioned close to the working Cam Units/ Force Cylinders. Drivers can be seated in any position to suit the design of the tool.
4. It is possible to add operations in existing tools to lower the costs of purchasing new tools
5. All units can be installed at any location and orientation to fit an existing tool, even upside-down
6. Built in safety feature against tool damage or over pressurisation of the system through the use of an Accumulator
7. Side load in the tool could be reduced because the Power Unit always works in a vertical direction
8. Even force distribution possible within the tool due to flexibility of Power Unit location
9. Increased quality of the produced parts and longer life of the punches is possible because the piercing is performed perpendicularly to the panel
10. The force of the Cam Unit/ Force Cylinders. can be altered to suit an operation by simply adjusting the nitrogen pressure in the Accumulator

Component selection

The following step by step instruction shows how to select the size of the units when taking into consideration the required forces, stroke length and the number of operations.

Step 1 (For piercing and cutting only)

Shear and stripping force calculations for piercing and cutting operations.

Sheet metal thickness..... : $t =$ _____ mm

Tensile strength..... : $\sigma =$ _____ N/mm²

Shearing strength ($\tau = \sigma \times 0.8$)..... : $\tau =$ _____ N/mm²

Diameter of punch : $d =$ _____ mm

(or)

Total cut length..... : $l =$ _____ mm

Piercing force F_p

Piercing a round hole

$$F_p = t \times \tau \times d \times \pi$$

Piercing or cutting

$$F_p = t \times \tau \times l$$

Example

Calculate force needed to pierce a $\varnothing 10.5$ mm hole in a 1.2 mm thick panel. Tensile strength is 400 N/mm². (Normally between 270 - 400 N/mm²).

$$F_p = 1.2 \times 400 \times 0.8 \times 10.5 \times \pi$$

$$F_p = 12667$$

$$F_p \approx 12.7 \text{ kN}$$

Stripping force F_s

$$F_s = F_p \times 0.11 \quad (\text{roughly 11\% of the required piercing force})$$

Example

$$F_s = 12667 \times 0.11$$

$$F_s = 1393$$

$$F_s \approx 1.4 \text{ kN}$$

Step 2 Size of Cam Unit/ Force Cylinder

Calculate the force required for the operation in the tool. Make sure to choose a Cam Unit/ Force Cylinder with enough force to perform the operation. If the amount of force required is a little uncertain it is better to use a larger size of Cam.

Required force (kN)	Cam Unit/ Force Cylinder
0-15	015
15-40	040
40-60	060
60-90	090
90-150	150

Example

Choose a Cam Unit 040 if the required force is 22 kN.

Step 3 Stroke length of Cam Unit/Force Cylinder

Check the necessary stroke of the Cam Unit/ Force Cylinder to perform the operation in the tool. Choose the shortest stroke length but make sure that there is enough room for the produced part in the tool.

Required stroke length (mm)	Max stroke length, Cam Unit (mm)	Max stroke length, force Cylinder (mm)
0-24	24	25
24-49	49	50
49-99	99*	100
99-150	124**	150

* This stroke length is not available for Compact Cam 015

**This stroke length is only available for Compact Cam 040

Example

If the required stroke is 35 mm choose a Cam Unit/Force Cylinder with 50 mm stroke length.

Required force:

_____ kN

Size Cam Unit/ Force Cylinder:

6

Stroke length Cam Unit/ Force Cylinder:

_____ mm

Step 4 Order number for the Cam Unit/Force Cylinder

Choose the Cam Unit/ Force Cylinder depending on the type of the operation.

See also page 9.2/2, 9.4/1 and 9.8/1.

Example

The order number for the 40kN Compact Cam with 49 mm stroke length will be CC 040-049.

Compact Cam:

CC _____ - _____

Flange Cam:

CCF _____ - _____

Force Cylinder:

HCF _____ - _____

6

Step 5a Size and stroke of Power Unit

Step 5a is valid when using 1-3 Cam Units/ Force Cylinders of equal sizes connected to one Power Unit. Step 5b is valid when different Cam Units/ Force Cylinders are connected to one single Power Unit.

Use the table below to choose the Power Unit. Read the table in the following order: Cam Unit/ Force Cylinder – Size – Stroke – Quantity – Power Unit. Check always that your available press stroke = used stroke Power Unit.

More than three Cam Units/ Force Cylinders connected to one Power Unit is not recommended.

Do not exceed the maximum Cam velocity, see also page 9.7/1.

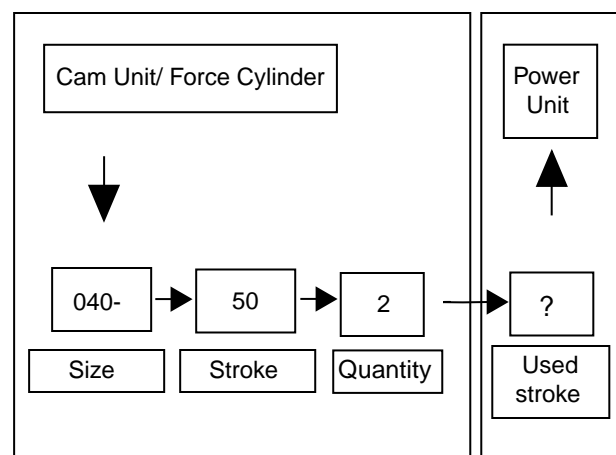



Flex Cam®

CAM UNIT / FORCE CYL.			POWER UNIT / Used stroke / Ratio CAM UNIT or FORCE CYL.-POWER UNIT																					
Size	Stroke	Qty	015- Stroke	Ratio	040- Stroke	Ratio	060- Stroke	Ratio	090- Stroke	Ratio	150- Stroke	Ratio	015- Stroke	Ratio	040- Stroke	Ratio	060- Stroke	Ratio	090- Stroke	Ratio	150- Stroke	Ratio		
015-	25	1	35	1.0	35	2.5	35	4.0	35	14	6.3	35	13	9.8										
	25	2	60	0.5	35	1.2	35	2.0	35	18	3.1	35	15	4.9										
	25	3	110	0.3	60	0.8	35	1.3	35	22	2.1	35	18	3.3										
	50	1	60	1.0	35	2.5	35	4.0	35	18	6.3	35	15	9.8										
	50	2	110	0.5	60	1.2	35	2.0	35	26	3.1	35	20	4.9										
	50	3				110	0.8	60	1.3	35	34	2.1	35	25	3.3									
	100	1	110	1.0	60	2.5	35	4.0	35	26	6.3	35	20	9.8										
	100	2				110	1.2	60	2.0	60	42	3.1	35	30	4.9									
	100	3				160	0.8	110	1.3	60	58	2.1	60	41	3.3									
	150	1	160	1.0	110	2.5	60	4.0	60	34	6.3	35	25	9.8										
150	2				160	1.2	110	2.0	60	58	3.1	60	41	4.9										
150	3								160	82	2.1	60	56	3.3										
040-	25	1	110	0.4	35	1.0	35	1.6	35	20	2.5	35	16	3.9										
	25	2			60	0.5	60	0.8	35	30	1.3	35	23	2.0										
	25	3			110	0.3	60	0.5	60	40	0.8	35	29	1.3										
	50	1			60	1.0	60	1.6	35	30	2.5	35	23	3.9										
	50	2			110	0.5	110	0.8	60	50	1.3	35	35	2.0										
	50	3			160	0.3	110	0.5	110	70	0.8	60	48	1.3										
	100	1			110	1.0	110	1.6	60	50	2.5	35	35	3.9										
	100	2							160	89	1.3	60	60	2.0										
	100	3								160	129	0.8	110	86	1.3									
	150	1							160	103	1.6	110	70	2.5										
	150	2								160	129	1.3	110	86	2.0									
	150	3											160	124	1.3									
	060-	25	1	110	0.3	60	0.6	35	1.0	35	26	1.6	35	20	2.4									
25		2			110	0.3	60	0.5	60	42	0.8	35	30	1.2										
25		3			160	0.2	110	0.3	60	58	0.5	60	41	0.8										
50		1			110	0.6	60	1.0	60	42	1.6	35	30	2.4										
50		2							110	74	0.8	60	51	1.2										
50		3							160	106	0.5	110	71	0.8										
100		1							110	74	1.6	60	51	2.4										
100		2								160	138	0.8	110	92	1.2									
100		3											160	133	0.8									
150		1							160	106	1.6	110	71	2.4										
150		2											160	133	1.2									
090-	25	1			110	0.4	60	0.6	35	35	1.0	35	26	1.6										
	25	2			160	0.2	110	0.3	60	60	0.5	60	42	0.8										
	25	3							160	85	0.3	60	58	0.5										
	50	1			160	0.4	110	0.6	60	60	1.0	60	42	1.6										
	50	2								110	0.5	110	74	0.8										
	50	3								160	0.3	110	106	0.5										
	100	1								110	1.0	110	74	1.6										
	100	2											160	138	0.8									
	150	1										150	160	1.0										
150-	25	1			110	0.3	110	0.4	60	49	0.6	35	35	1.0										
	25	2							160	88	0.3	60	60	0.5										
	25	3								127	0.2	110	85	0.3										
	50	1							160	88	0.6	60	60	1.0										
	50	2										110	110	0.5										
	50	3										160	160	0.3										
	100	1										110	74	1.6										
	150	1											160	160	1.0									

6

Combinations of Cam Units and Power Unit marked are normally not recommended as maximum Cam velocities can be exceeded if Power Unit is stroked too quickly. See also the following examples.

See also the following examples:

Example 1.

If you have chosen one Compact Cam Unit CC 040-049 the normal Power Unit will be HCP 040-060. The used stroke of the Power Unit is 60 mm. The ratio will be 1.0 which gives the same Compact Cam stroke velocity as the press.

(Press stroke 10 mm - Cam stroke 10 mm).

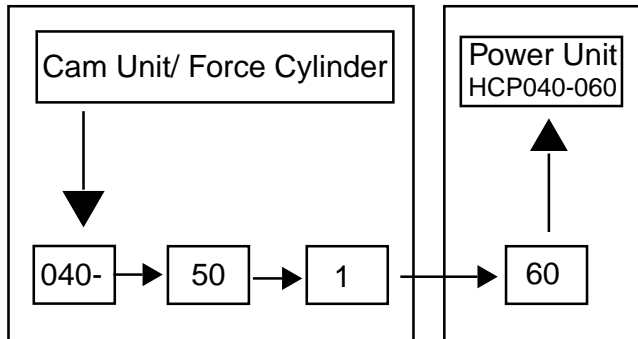

Example 2.

If it is possible to use only 30 mm of stroke from the press to perform an operation, choose a larger Power Unit HCP 090-035 connected to one Cam Unit CC 040-049. The used stroke of the Power Unit will be 30 mm and the ratio 2.5. If the press speed is 0.3 m/s the Cam speed will be $2.5 \times 0.3 = 0.75$ m/s.

(Press stroke 10 mm - Cam stroke 25 mm).

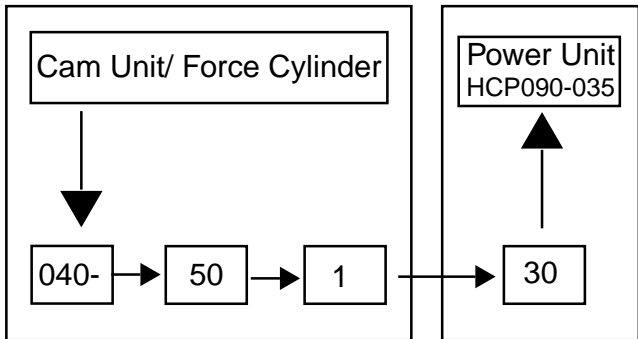

The used stroke of the Power Unit and the Cam Unit/ Force Cylinder can always be optimised to suit the situation in the tool. In some installations it is necessary to increase the velocity of the Cam relative to the press. Note that the movement of the Cams during the stroke is not equal when more than one cam is connected to the Power Unit.

Example 3.

If you choose to use two Cam Units of size CC 040-049 and have a possible 110 mm of the press stroke available then use Power Unit HCP 040-110. The used stroke of the Power Unit will be 110 mm and the ratio 0.5.

If the press speed is 0.3 m/s the medium velocity of the Cams will be $0.5 \times 0.3 = 0.15$ m/s.

(Press stroke 10 mm - Cam stroke approximately 5 mm).

Power Unit order number:

See also page 9.4/1 and 9.8/1.

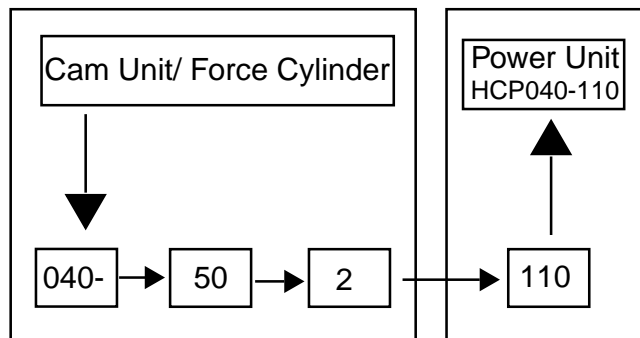

Power Unit:

HCP _____ - _____

Step 5b Size and stroke of Power Unit using different sizes of Cam Units/ Force Cylinders

Determine first the total oil volume for the Cam Units/ Force Cylinders using the formula below. The total oil volume is the sum of the volumes of all Cam Units/ Force Cylinders. The volume is the piston area times the used stroke. The total oil volume V_c for the Cam Units/ Force Cylinders = minimum oil volume for the Power Unit in dm^3 . A_n is the piston area in the Cam Units in dm^2 as shown in Table 1.

$$V_c = ((A_1 \times S_1) + (A_2 \times S_2) \dots (A_n \times S_n)) / 100$$

A_n = Area, Cam Unit

S_n = Stroke length, Cam Unit

Choose the appropriate Power Unit from Table 2. The Power Unit has to give at least the minimum volume of oil as calculated above. Calculate the used stroke S_p of the Power Unit using the formula below:

$$S_p = ((V_c / V_{HCP}) * S_{HCP}) + 10$$

V_c = Total oil volume Cam Units/ Force Cyl.

V_{HCP} = Oil volume Power Unit

S_{HCP} = Stroke Power Unit

Note, the additional 10 mm is required so that a precise Cam stroke is performed. See 9.3/1 for a Function Description.

See also the following example:

Choose a Power Unit to supply one Compact Cam CC 015-049 and one Force Cylinder HCF 040-050 with only 40 mm used stroke.

$$V_c = ((A_{CC} \times S_{CC}) + (A_{HCF} \times S_{HCF})) / 100$$

$$V_c = ((0.13 \times 49) + (0.31 \times 40)) / 100$$

(See Table 1)

$$V_c = 0.189$$

Table 1. Piston area for the Cam Units/ Force Cylinders

CC HCF	015	040	060	090	150
A_n (dm^2)	0.13	0.31	0.50	0.79	1.23

Total oil volume Cam Units/ Force Cylinders:

$$V_c = \underline{\hspace{2cm}} \text{dm}^3$$

6

Table 2. Oil volume Power Unit V_{HCP}

Stroke length S_{HCP}	HCP				
	015	040	060	090	150
25 mm	0.031	0.078	0.126	0.196	0.307
50 mm	0.063	0.156	0.251	0.393	0.614
100 mm	0.126	0.312	0.502	0.785	1.227
150 mm	0.188	0.468	0.753	1.178	1.841

Used stroke Power Unit:

$$S_p = \underline{\hspace{2cm}} \text{mm}$$

Choose a Power Unit with more than 0.189 dm³ oil volume for example HCP 060-60 which has 0.251 dm³. (Another alternative HCP 040-110.) Calculate used stroke of the Power Unit:

$$S_p = ((V_c / V_p) \times S_{HCP}) + 10$$

$$S_p = ((0.189 / 0.251) \times 50) + 10$$

$$S_p = 48 \text{ mm}$$

In the above example, a Power Unit HCP 060-060 is recommended with a used stroke of 48 mm. Do not exceed the specified velocity of the Cam Units/ Force Cylinders according to page 9.7/1 "Technical data". Remember also that one of the Cams will move slightly before the other one when using two Cams coupled to one Power Unit.

Step 6

Choose hose and adapters according to page 9.8/27 "Dimensions for accessories".

Maximum hose length between Power Unit and Cam Unit is 2 m. The size of the hose is always set by the size of the Power Unit. The size of the hose is adapted for the oil flow according to the velocities in page 9.7/1 "Technical data".

If you need a smaller hose than our normal specifications, check your press velocity and refer to Table 1 or page 9.8/37.

It is easiest to choose the correct hose length when the Cam Unit/ Force Cylinder and the Power Unit are installed in the tool.

Make sure that the hose is long enough and is protected against sharp edges and external damage. The hose will flex a little due to the oil pressure pulsation during operation. Make sure the minimum bending radius of the hoses when installed are not below that which is specified.

Table 1

Power Unit	Hose size - Press velocity			
	Standard size Max velocity 0.8 m/s	0.6 m/s	0.4 m/s	0.2 m/s
HCP 015	1/2"	3/8"	3/8"	3/8"
HCP 040	3/4"	3/4"	1/2"	1/2"
HCP 060	1"	3/4"	3/4"	1/2"
HCP 090	1"	1"	3/4"	1/2"
HCP 150	1 1/4"	1 1/4"	1"	3/4"

Technical data

Capacity and performance

The forces in the table below are valid when the following normal gas pressures are used

Accumulator	150 bar
Force Cylinder	20 bar
CC 015-040, CCF 040 Return spring M2 200	180 bar
CC 060 Return springs X 350	180 bar
CC 090 Return spring TU 500	150 bar
CC 150 Return spring X 750	150 bar

Description	Unit	Force Cylinder					Compact Cam					Flange Cam	Power Unit				
		HCF					CC					CCF	HCP				
Force (size)	kN	15	40	60	90	150	15	40	60	90	150	40	15	40	60	90	150
Working return force (min)	kN	1.5	4	6	9	14	2	4	7	10	15	4	---	---	---	---	---
Max frequency	op/min	60			30	60			30	60	60			30			
Max velocity	m/s	0.8					0.8					0.8	0.8				
Max return velocity	m/s	0.8					0.8					0.8	0.8				
Min gas pressure	bar	10					125			105	125	50					
Max gas pressure	bar	40					180			150	180	180					
Stroke length	mm	25, 50, 100, 150					24, 49, 99*, 124**					49, 99	35, 60, 110, 160				
Expected life time	op.	1x10 ⁶					1x10 ⁶					1x10 ⁶	1x10 ⁶				
Surrounding temp	°C	10-40					10-40					10-40	10-40				

* not CC 015

** only CC 040

Other values than those specified in the table above could be accepted under special conditions or combinations of stroke length, velocity and frequency.

Other specifications

The hydraulic oil Shell Tellus TX 32 is the recommended oil as defined below:

DIN 51524 HVLP ISO VG 32

Purity ISO 4406 15/12 (with 10µm filter)

Nitrogen:

Nitrogen N₂ >99.95 vol %

Water H₂O < 40 ppm

Cam Unit/ Force Cylinder force as a function of nitrogen pressure in the Accumulator

If you need to increase or decrease the force of the Cam Unit/ Force Cylinder, it is possible to change the nitrogen pressure according to the diagram below.

Example.

A Force Cylinder size 040 is used to perform a forming operation. With the normal Accumulator charge pressure of 150 bar, this Force Cylinder gives 40 kN. If 25 kN of force is required then the Accumulator charge pressure should be reduced to 100 bar instead.

7

Force Cam Unit/ Force Cylinder - Nitrogen Pressure Accumulator

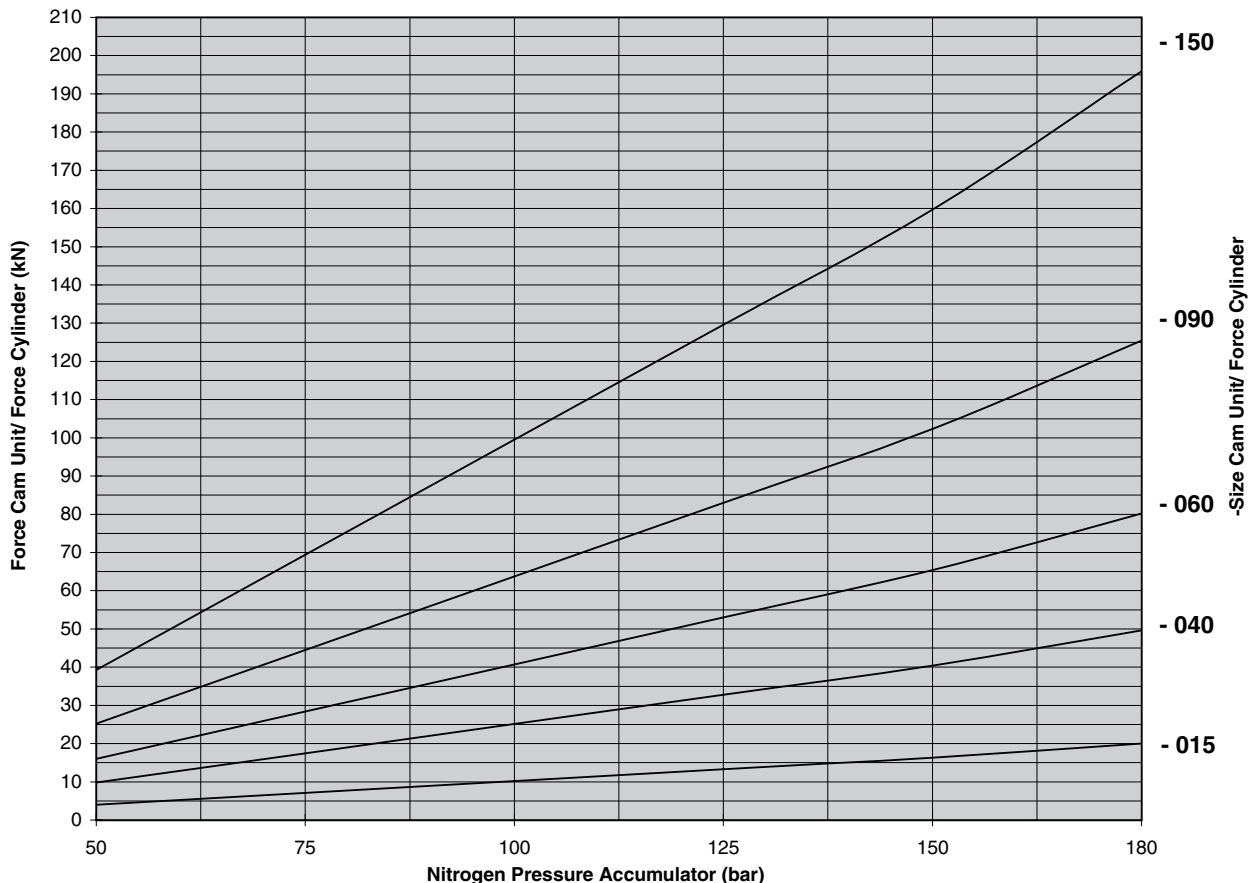

Dimensions for Power and Cam Units/ Force Cylinder

HCP 015 Power Unit

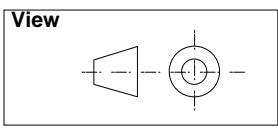
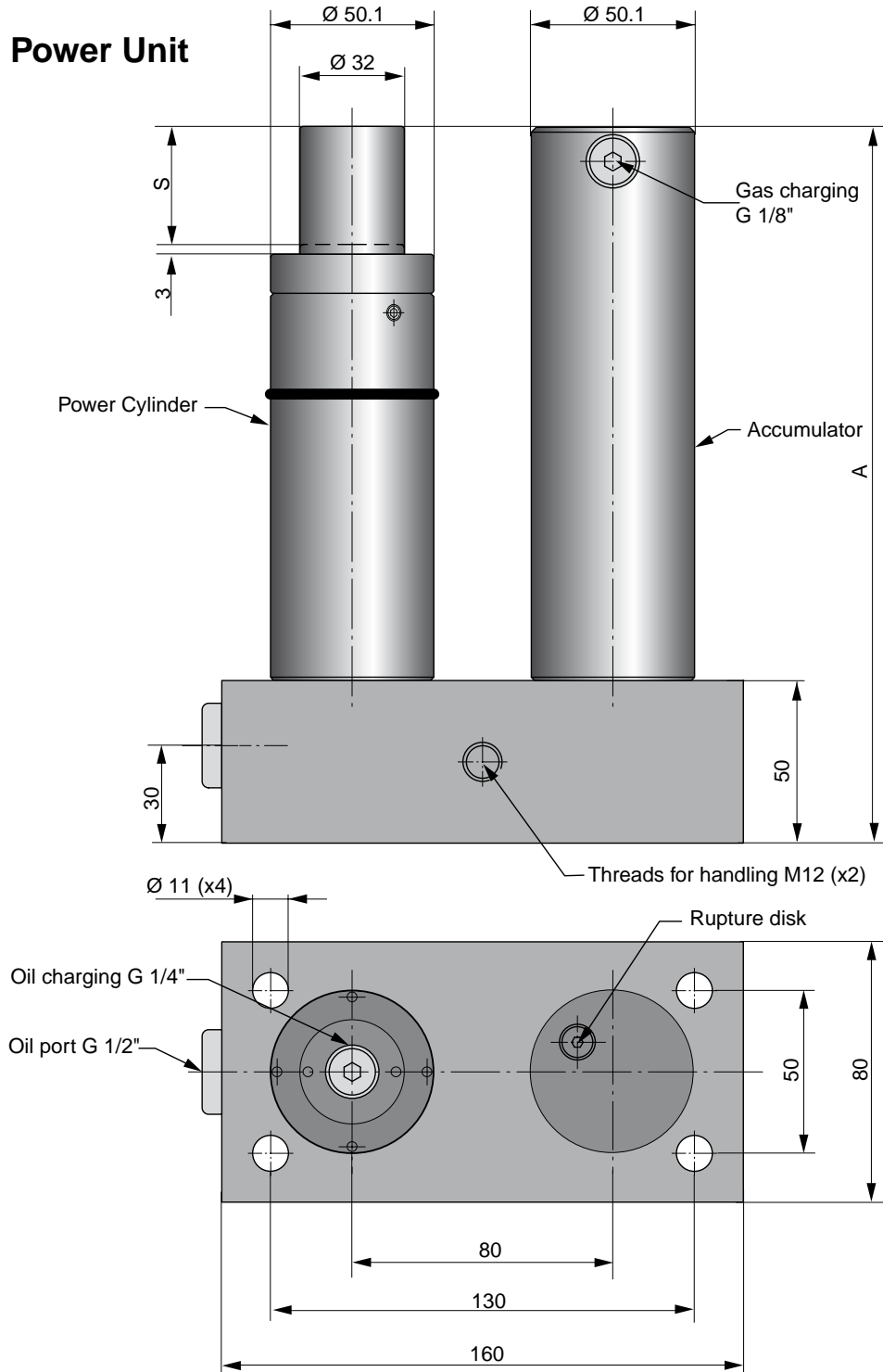

Volvo Part No.	Order No.	Force (kN)	Stroke S (mm)	A	Weight (kg)
3054893	HCP 015-035	15	35	220	8.2
3054906	HCP 015-060	15	60	270	9.1
3054907	HCP 015-110	15	110	370	10.5
3054908	HCP 015-160	15	160	470	11,3

HCP-S 015 Power Unit, with Separate Accumulator

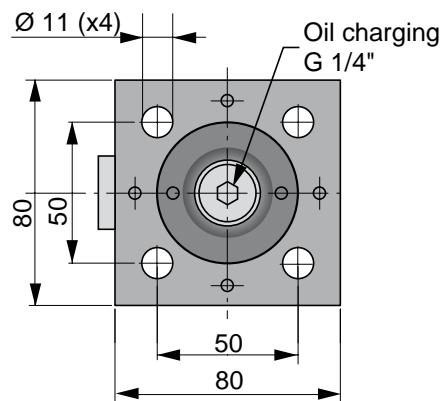
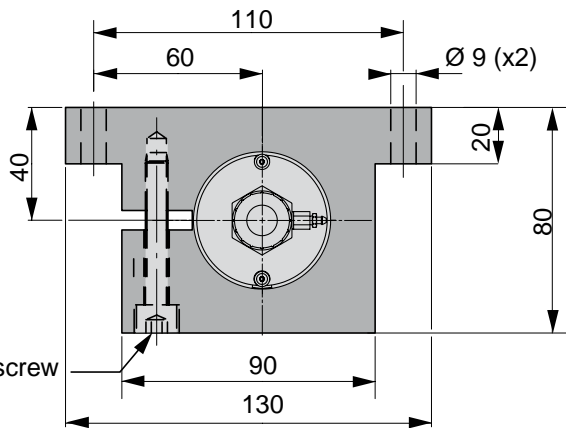
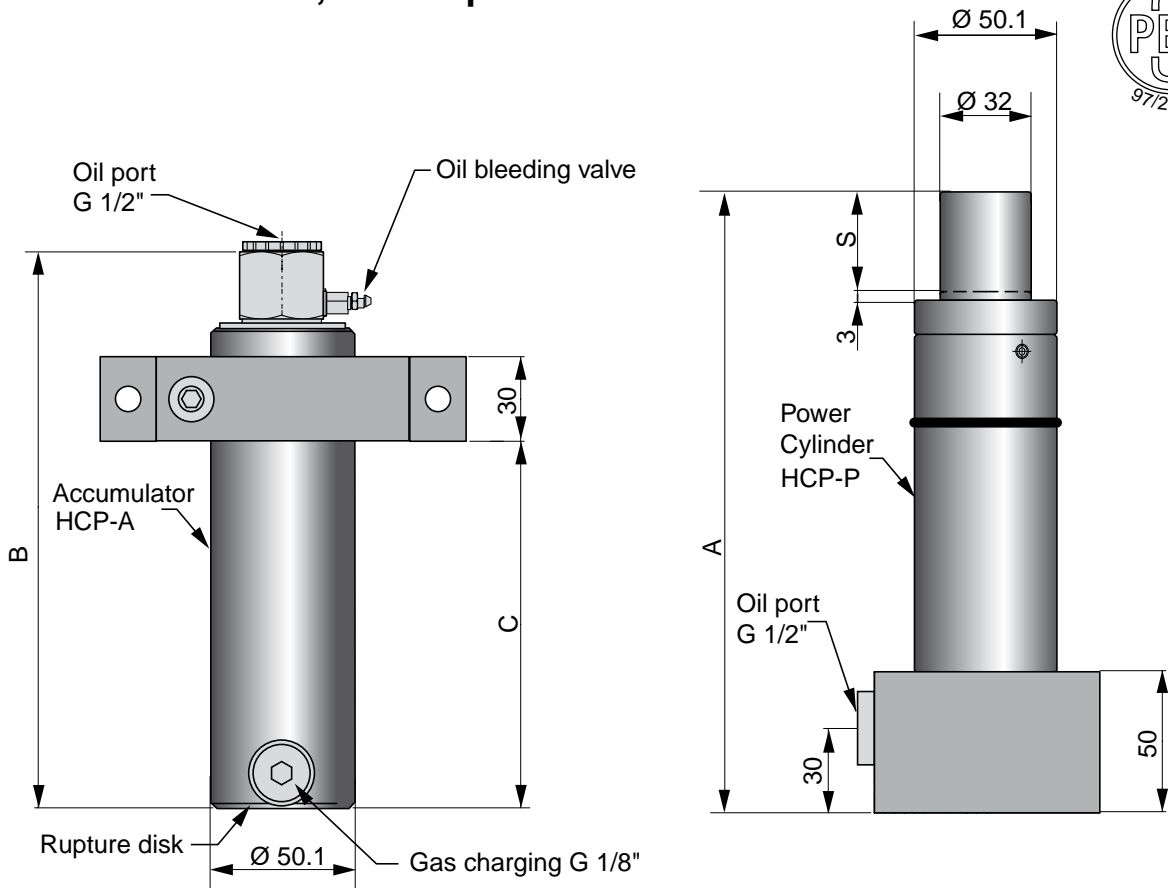

Note! The Mounting screw (M8) should be tightened with torque 25Nm

Volvo Part No.	Order No. Complete Power Unit HCP-S	Weight (kg)	Force (kN)	Stroke S (mm)	A	B	C	Volvo Part No.	Order No. Separate Power Cylinder HCP-P	Weight (kg)	Volvo Part No.	Order No. Separate Accumulator HCP-A	Weight (kg)
	HCP-S 015 - 035	7.3	15	35	220	213	130	3054909	HCP-P 015 - 035	4.3	3054913	HCP-A 015 - 035	3.0
	HCP-S 015 - 060	8.1	15	60	270	264	180	3054910	HCP-P 015 - 060	4.7	3054914	HCP-A 015 - 060	3.4
	HCP-S 015 - 110	9.6	15	110	370	364	280	3054911	HCP-P 015 - 110	5.5	3054915	HCP-A 015 - 110	4.1
	HCP-S 015 - 160	10.7	15	160	470	464	380	3054912	HCP-P 015 - 160	6.0	3054916	HCP-A 015 - 160	4.7

Note! The Accumulator should always be used in the system.

CC 015 Compact Cam

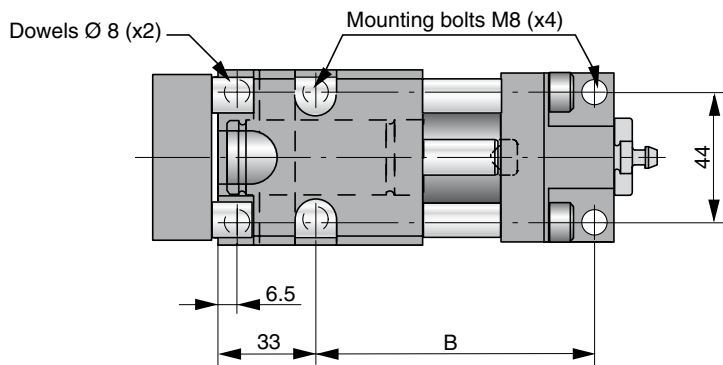
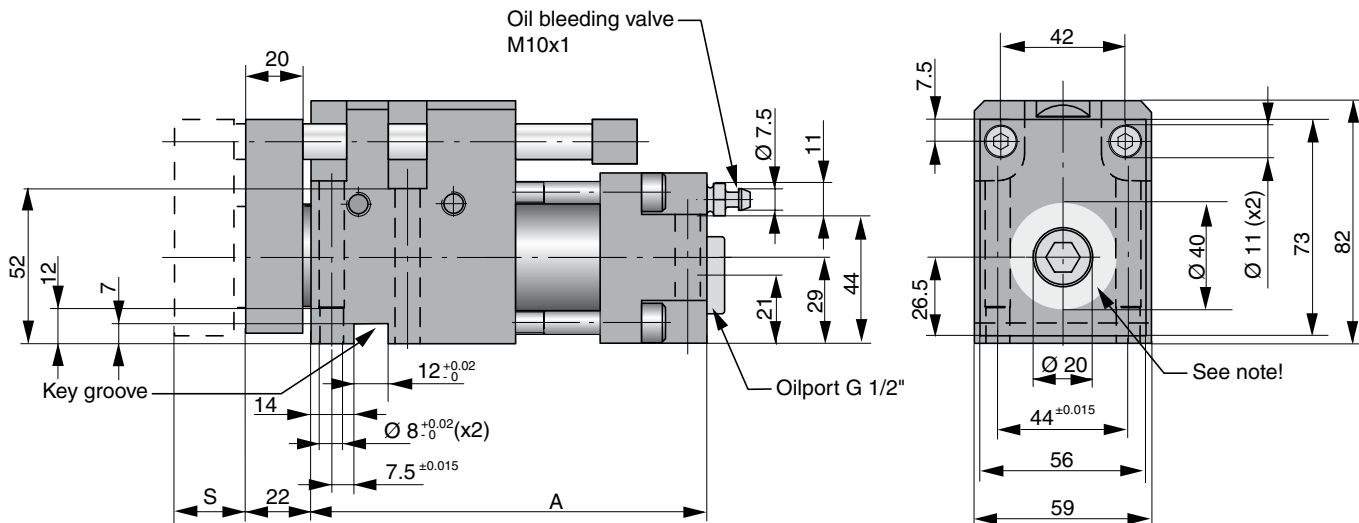

Note! Important installation information:

We recommend locating the punch in the centre of the piston rod, but it is also possible to locate the force which the punch or punches will create during the operations within the area marked .

When piercing an opened hole or cutting an edge we recommend that extra guiding is used to prevent the unit against sideload.

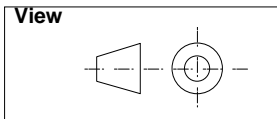

Volvo Part No.	Order No.	Working force* (kN)	Return force (kN)	Stroke S (mm)	A	B	Weight (kg)
3054905	CC 015-024	15	1.5	24	133.5	94	4.2
3054917	CC 015-049	15	1.5	49	158.5	119	4.6

* = Nominal force available for the operation

CC-H 015 Compact Cam for pressure control



This version can only be used together with a hose system as there are no gas charging valves in the springs or adapters

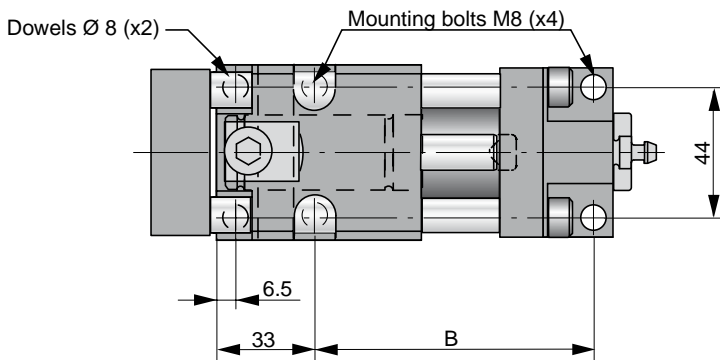
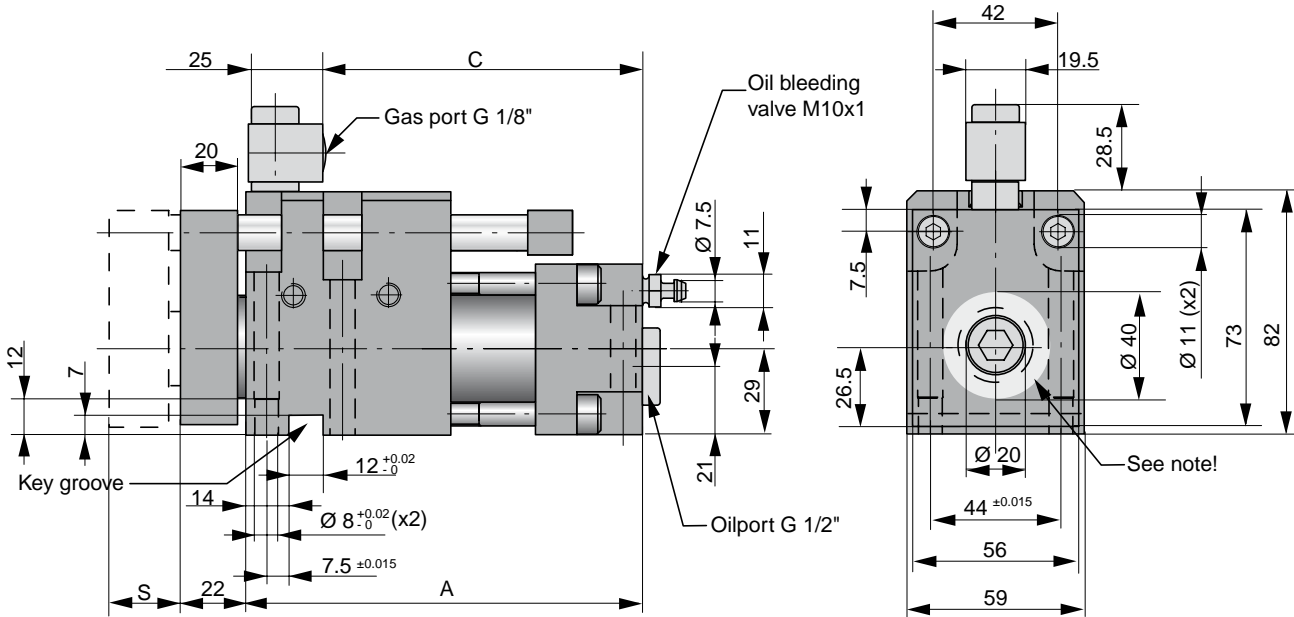

Note! Important installation information:

We recommend locating the punch in the centre of the piston rod, but it is also possible to locate the force which the punch or punches will create during the operations within the area marked .

When piercing an opened hole or cutting an edge we recommend that extra guiding is used to prevent the unit against sideload.

Volvo Part No.	Order No.	Working force* (kN)	Return force (kN)	Stroke S (mm)	A	B	C	Weight
	CC-H 015-024	15	1.5	24	133.5	94	107	4.3
	CC-H 015-049	15	1.5	49	158.5	119	132	4.7

* = Nominal force available for the operation

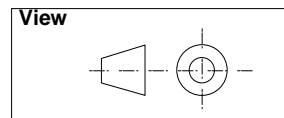



HCF 015 Force Cylinder

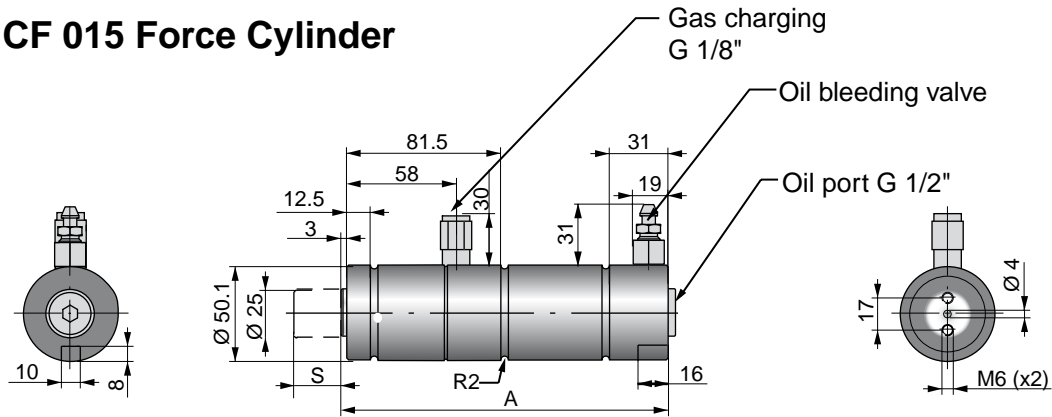

Volvo Part No.	Order No.	Working force* (kN)	Return force* (kN)	Stroke S (mm)	A	Weight (kg)
3054918	HCF 015-025	15	3	25	173	2.0
3054919	HCF 015-050	15	3	50	223	2.5
3054920	HCF 015-100	15	3	100	323	3.6
3054921	HCF 015-150	15	3	150	423	4.6

* = Nominal force for the operation

Flange mount HCF 015 Order No. 2014677-0750 (Mount only) Volvo Part No. 3044691

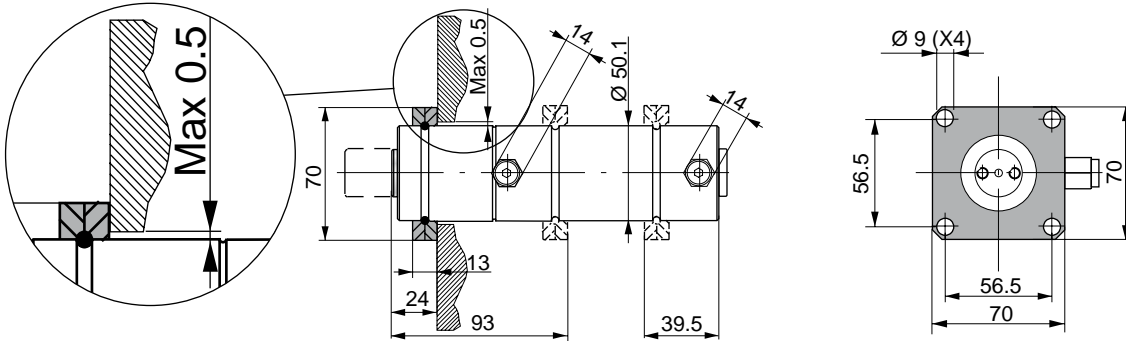

Foot mount HCF 015 Order No. 3016977-015 (Mounts only)

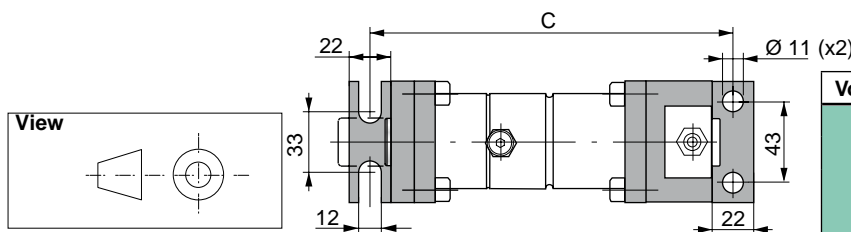
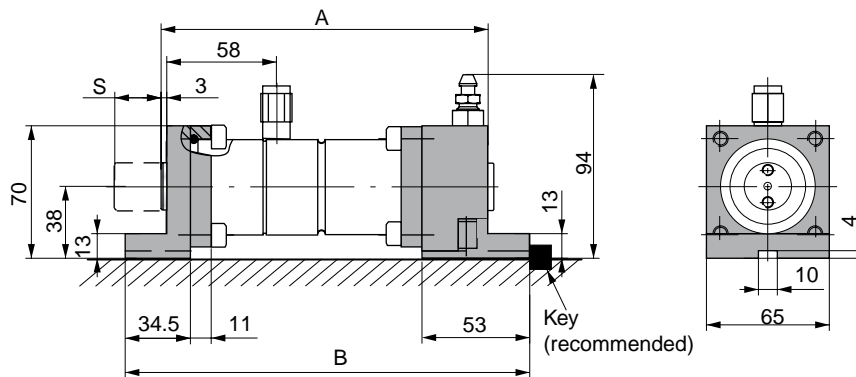

Volvo Part No.	Model	A	B	C
3054922	HCF 015-125	173	214	192
	HCF 015-050	223	264	242
	HCF 015-100	323	364	342
	HCF 015-150	423	464	442

HCF-SP 015

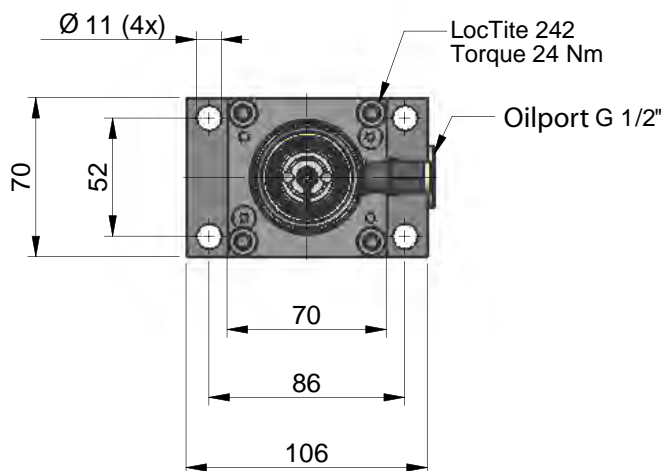
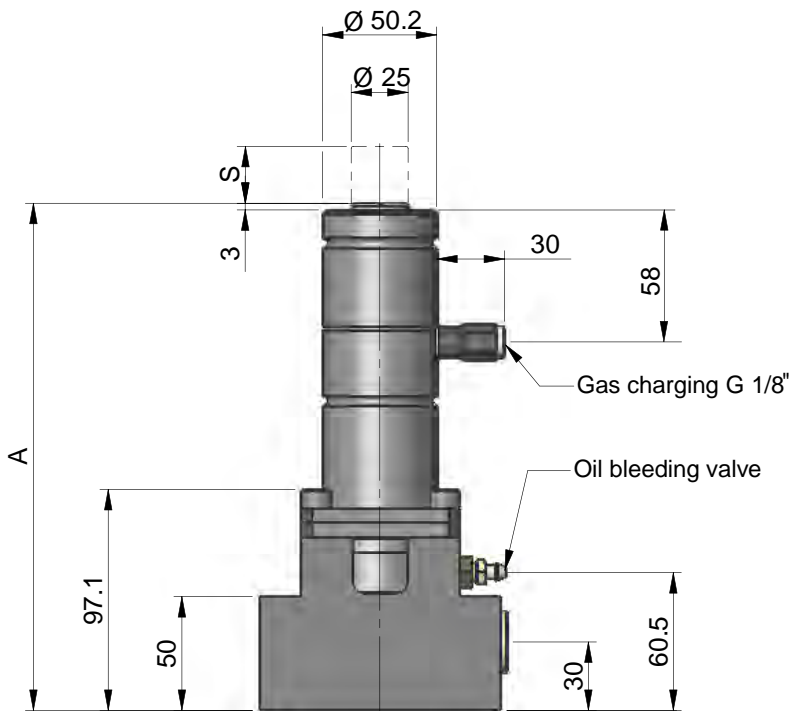
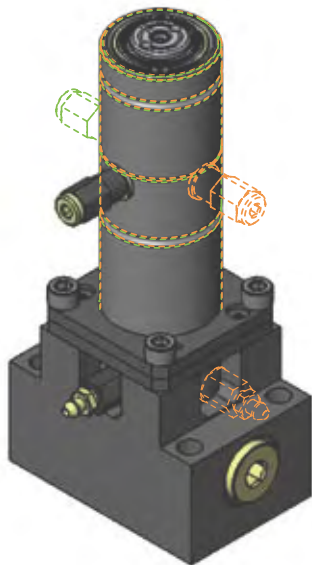

Volvo Part No.	Order No.	Working force* (kN)	Stroke S (mm)	A	Weight [kg]
3054923	HCF-SP 015-025	15	25	248	5.6
3054924	HCF-SP 015-050	15	50	323	6.1
3054925	HCF-SP 015-100	15	100	473	7.1
3054926	HCF-SP 015-150	15	150	623	8.2

*= Nominal force for the operation

HCP 040 Power Unit

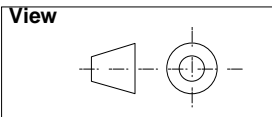
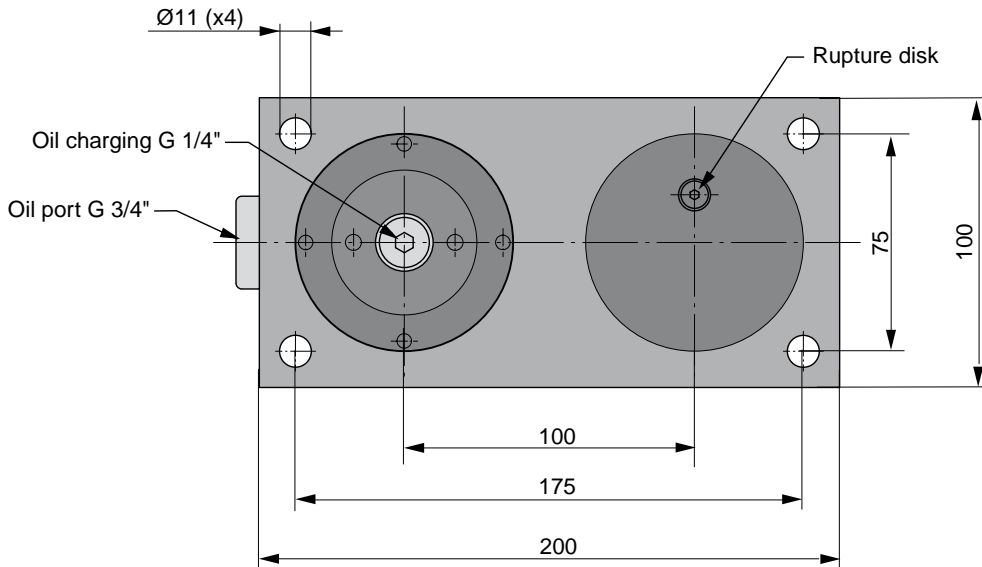
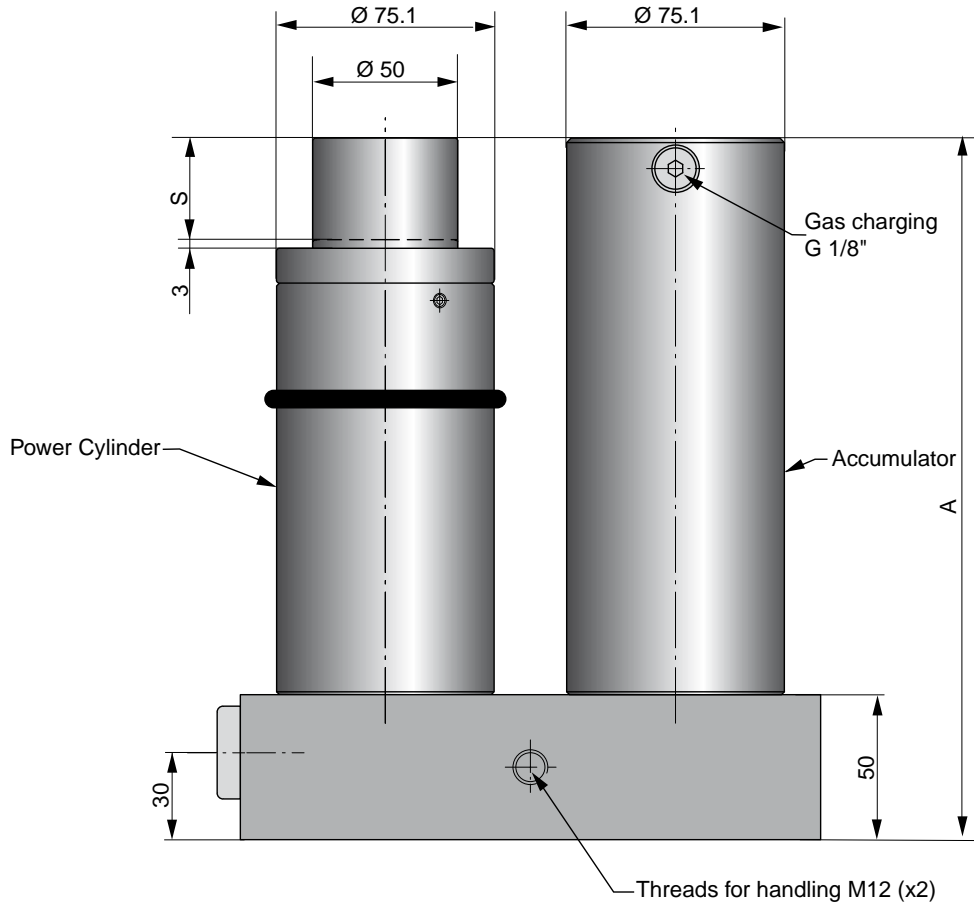

Volvo Part No.	Order No.	Force (kN)	Stroke S (mm)	A	Weight (kg)
3054927	HCP 040-035	40	35	242	15.7
3054928	HCP 040-060	40	60	292	16.8
3054929	HCP 040-110	40	110	392	19.1
3054930	HCP 040-160	40	160	492	21.3

HCP-S 040 Power Unit, with Separate Accumulator

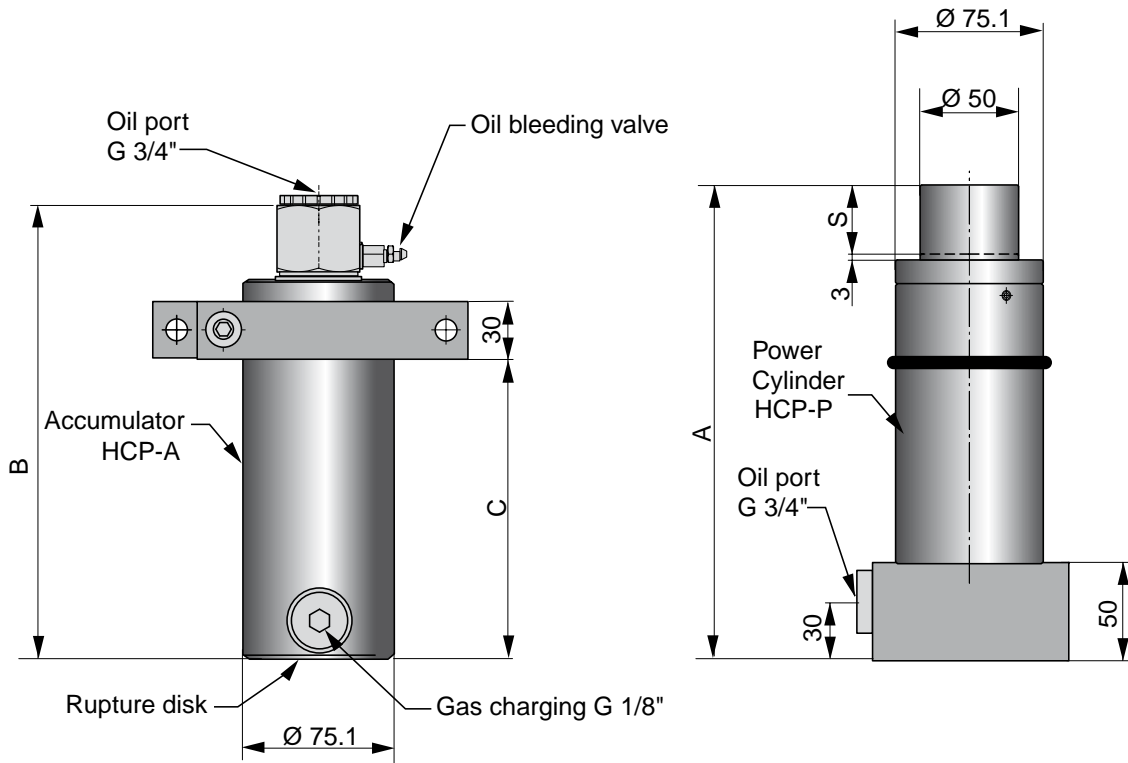

8

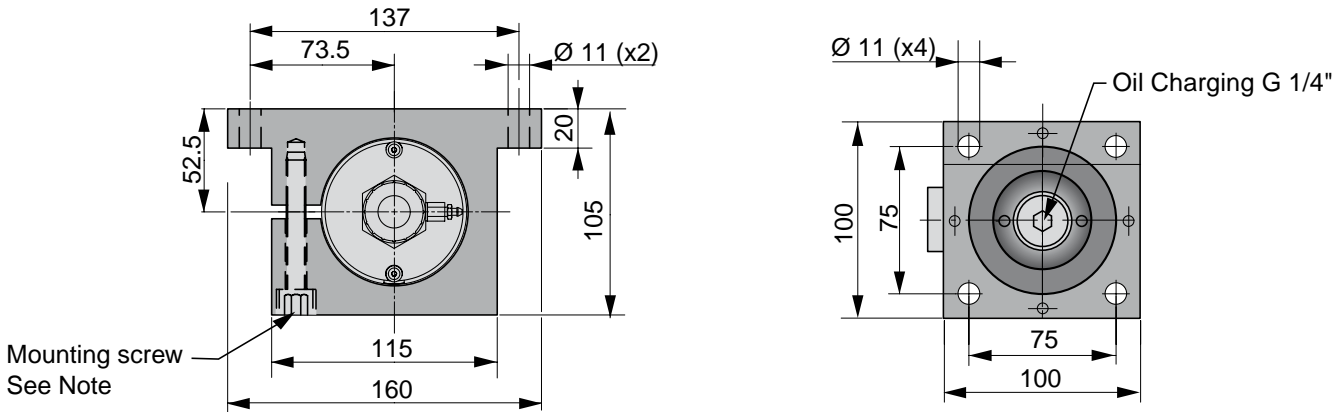

Note! The mounting screw (M10) should be tightened with torque 52Nm.

Volvo Part No.	Order No. Complete Power Unit HCP-S	Weight (kg)	Force (kN)	Stroke S (mm)	A	B	C	Volvo Part No.	Order No. Separate Power Cylinder HCP-P	Weight (kg)	Volvo Part No.	Order No. Separate Accumulator HCP-A	Weight (kg)
	HCP-S 040 -035	14.0	40	35	242	231	152	3054935	HCP-P 040 -035	8.2	3054931	HCP-A 040 -035	5.8
	HCP-S 040 -060	15.0	40	60	292	281	202	3054936	HCP-P 040 -060	8.7	3054932	HCP-A 040 -060	6.3
	HCP-S 040 -110	17.4	40	110	392	381	302	3054937	HCP-P 040 -110	10.0	3054933	HCP-A 040 -110	7.4
	HCP-S 040 -160	19.6	40	160	492	481	402	3054938	HCP-P 040 -160	11.2	3053934	HCP-A 040 -160	8.4

Note! The Accumulator should always be used in the system.

CC 040 Compact Cam

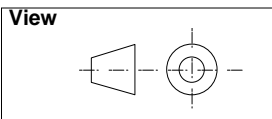
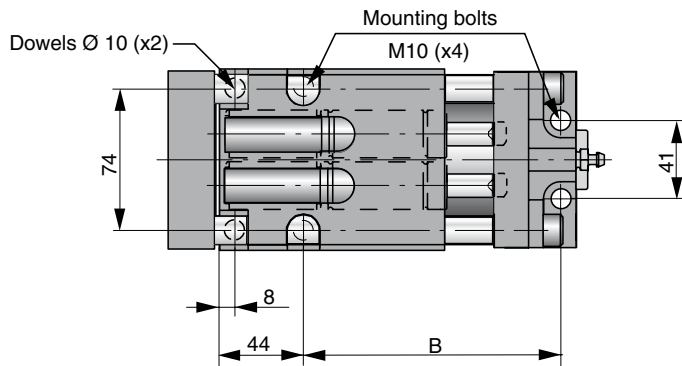
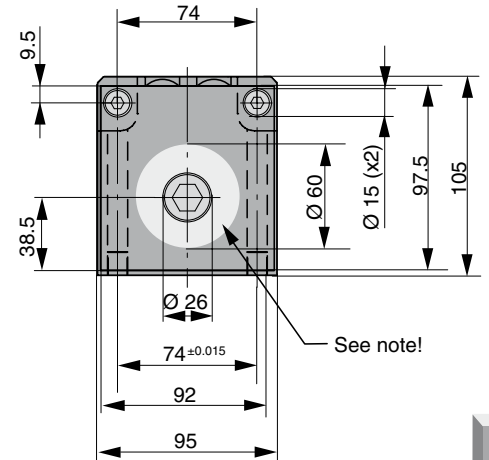
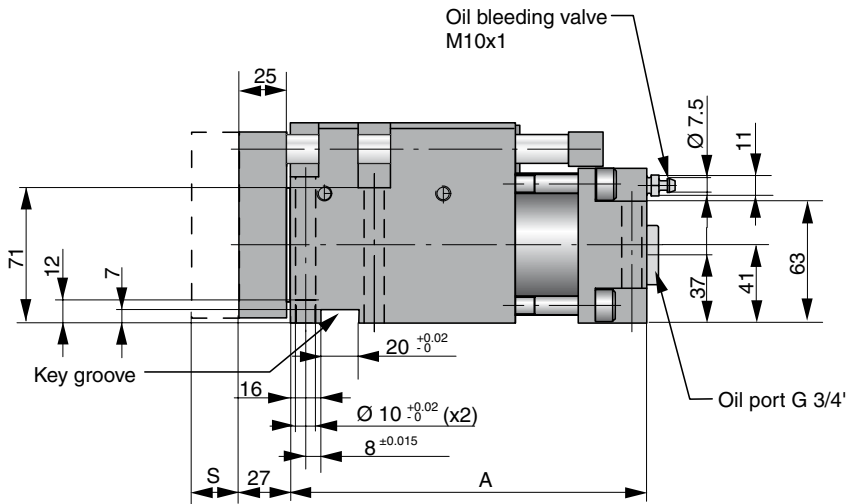

Note!
Important installation information:

We recommend locating the punch in the center of the piston rod, but it is also possible to locate the force which the punch will create in the operations within the area marked .

When piercing an opened hole or cutting an edge we recommend that extra guiding is used to prevent the unit against sideload.

Volvo Part No.	Order No.	Working force* (kN)	Return force (kN)	Stroke S (mm)	A	B	Weight (kg)
3054939	CC 040-024	40	4	24	187	135	10.5
3054940	CC 040-049	40	4	49	212	160	12.8
3054941	CC 040-099	40	4	99	262	210	15.0
3054942	CC 040-124	40	4	124	287	235	16.5

* = Nominal force available for the operation

CC-H 040 Compact Cam for pressure control



This version can only be used together with a hose system as there are no Gas Charging valves in the springs or adapters

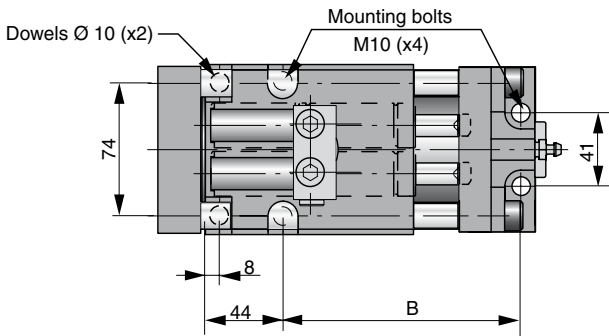
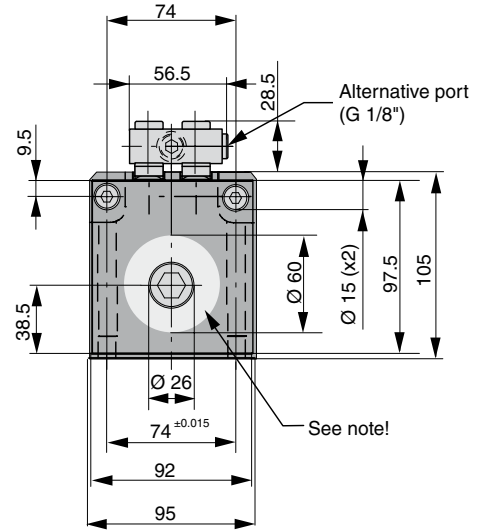
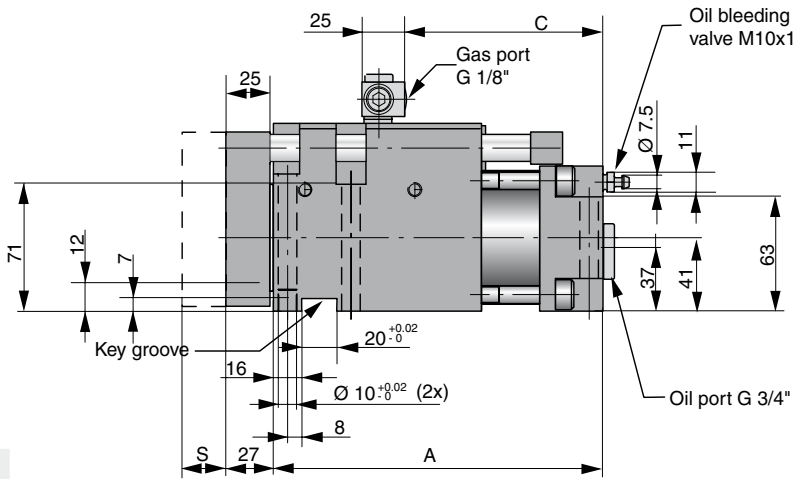

Note! Important installation information:

We recommend locating the punch in the centre of the piston rod, but it is also possible to locate the force which the punch will create in the operations within the area marked .

When piercing an opened hole or cutting an edge we recommend that extra guiding is used to prevent the unit against sideload.

Note! There are two G1/8" gas ports which can be used to couple the hose system to. Use only one of these to connect the hose, the other should remain plugged.

Volvo Part No.	Order No.	Working force* (kN)	Return force (kN)	Stroke S (mm)	A	B	C	Weight (kg)
	CC-H 040-024	40	4	24	187	135	112	10.7
	CC-H 040-049	40	4	49	212	160	162	13.0
	CC-H 040-099	40	4	99	262	210	237	15.2
	CC-H 040-124	40	4	124	287	235	262	16.7

* = Nominal force available for the operation

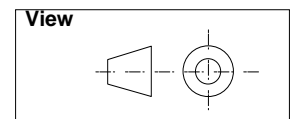

CCF 040 Flange Cam

Patent No. SE 513031, EP 1212156

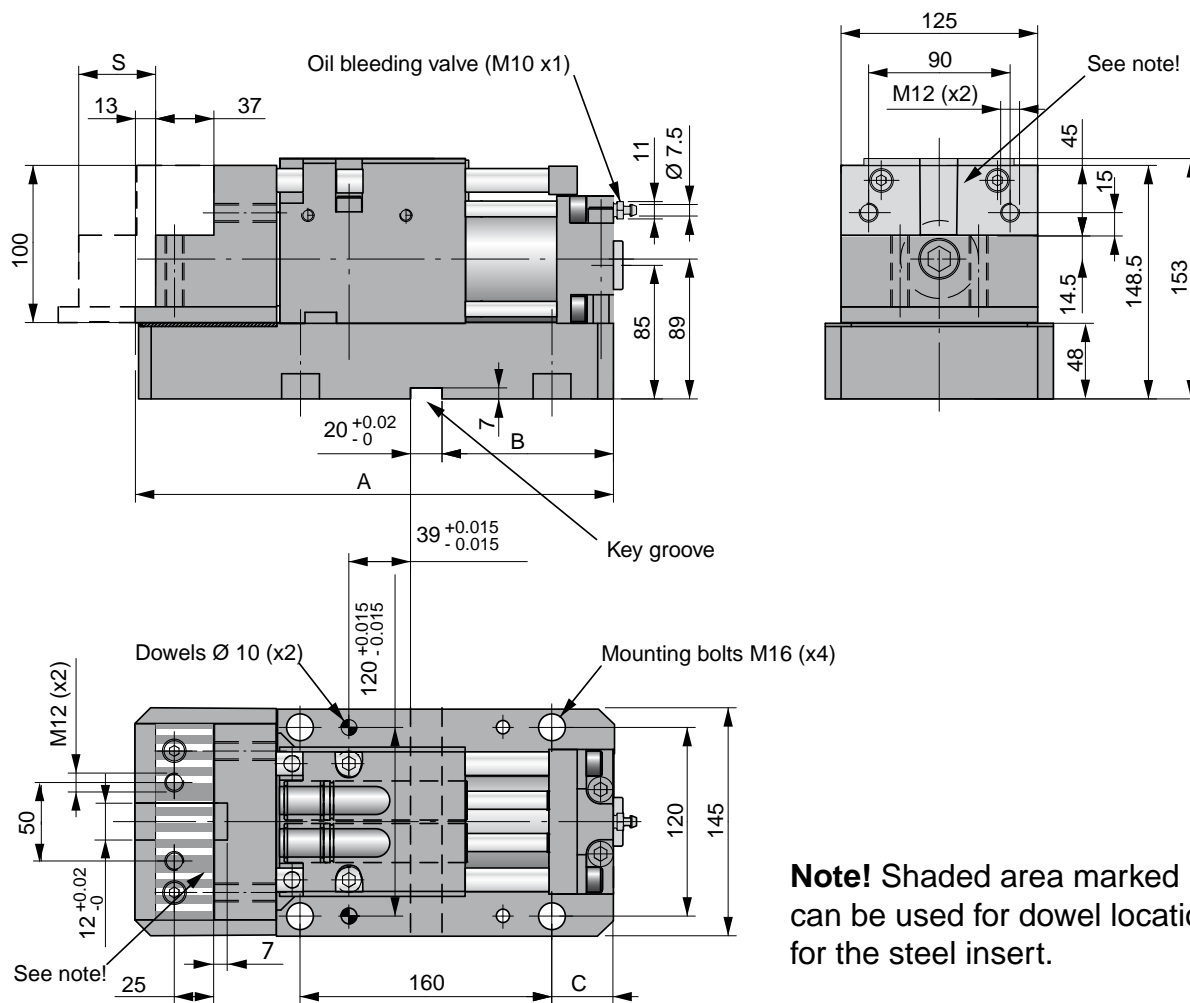

Note! Shaded area marked can be used for dowel location for the steel insert.

Shaded area marked is not to be machined for risk of damage to underlying roller bearings.

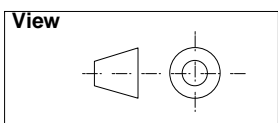

Volvo Part No.	Order No.	Working force* (kN)	Return force (kN)	Stroke S (mm)	A	B	C	Weight (kg)
3054943	CCF 040-049	40	4	49	304	109	39	35
3054944	CCF 040-099	40	4	99	404	159	89	43

* = Nominal force available for the operation



CCF-H 040 Flange Cam

Patent No. SE 513031, EP 1212156

This version can only be used together with a hose system as there are no gas charging valves in the springs or adapters

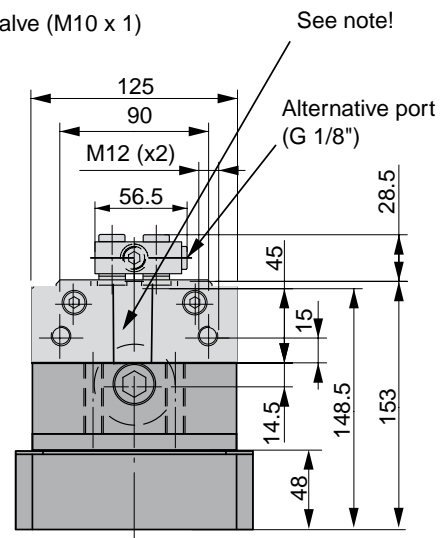
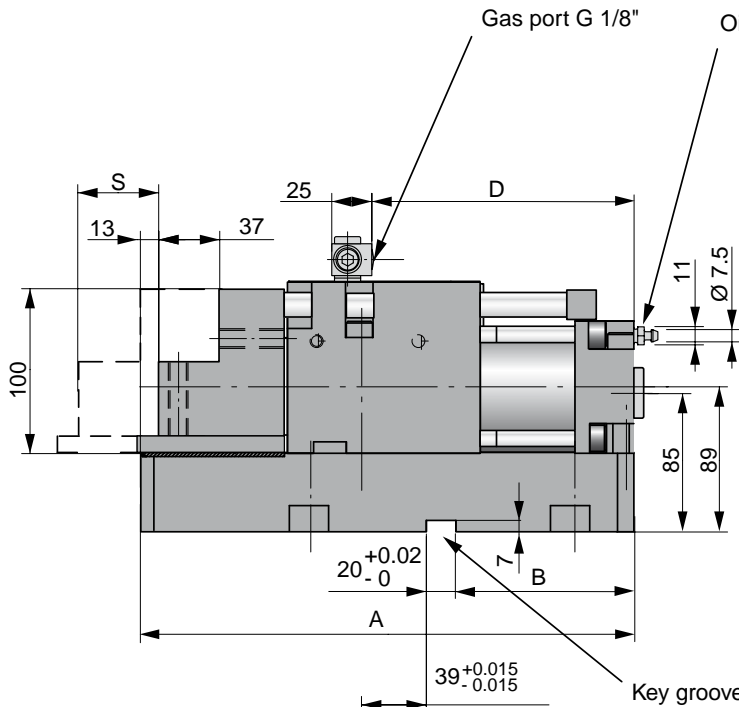

Note! Shaded area marked can be used for dowel location for the steel insert.

Shaded area marked is not to be machined for risk of damage to underlying roller bearings.

There are two G 1/8" gas ports which can be used to couple a hose system to. Use only one of these to connect the hose system, the other should remain plugged.

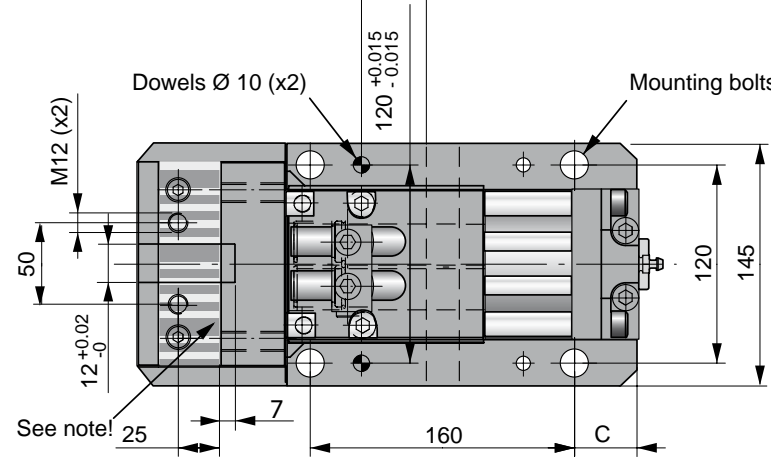

Volvo Part No.	Order No.	Working force* (kN)	Return force (kN)	Stroke S (mm)	A	B	C	D	Weight (kg)
	CCF-H 040-049	40	4	49	304	109	39	162	35
	CCF-H 040-099	40	4	99	404	159	89	237	43

* = Nominal force available for the operation



Top mount kit for Flange Cam
CCF 040-049 and CCF-H 040-049
CCF 040-099 and CCF-H 040-099

(Order No. 2018393)

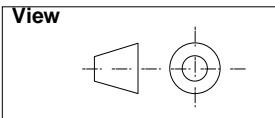
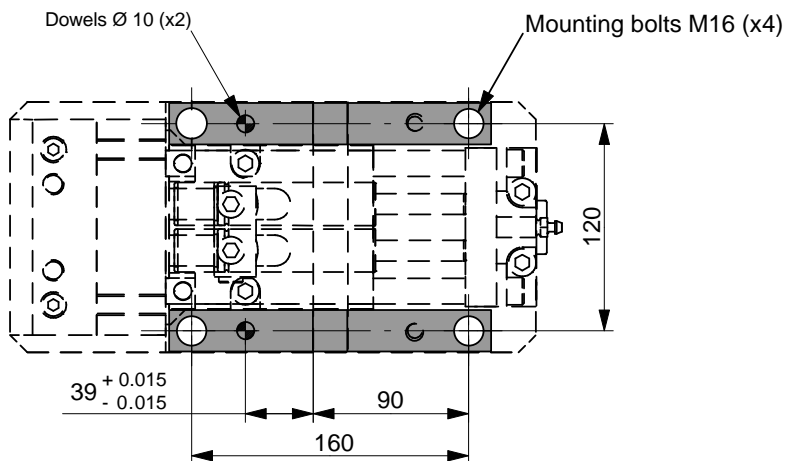
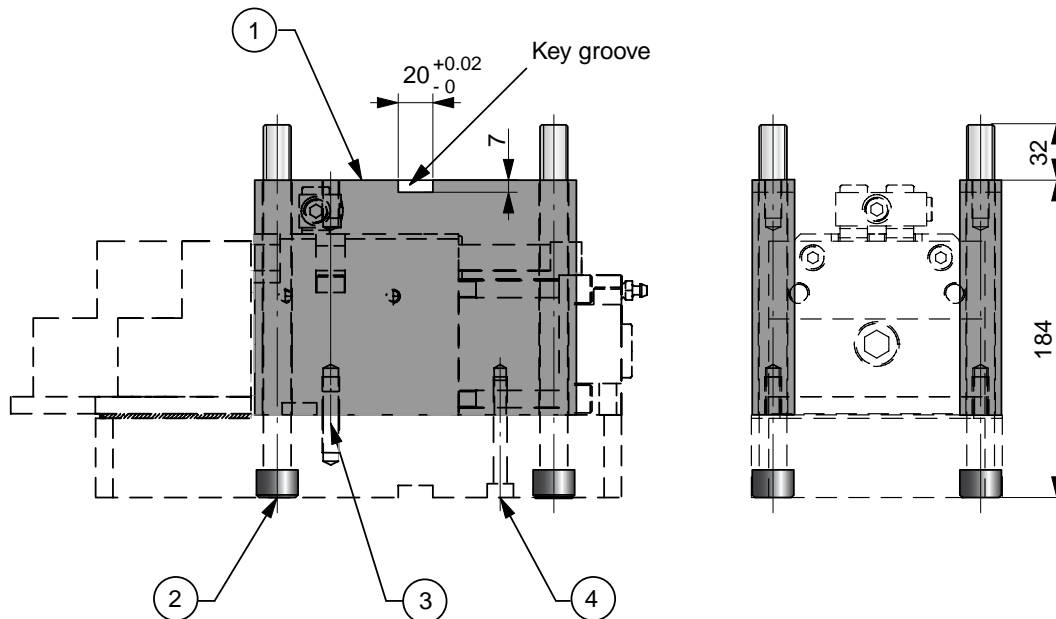

Position	Quantity	Description
1	2	Spacer
2	4	Bolt M16 x 200
3	2	Dowel pin Ø 10 x 40
4	2	Bolt M8 x 60

* = Nominal force available for the operation

Flange Cam installation possibilities

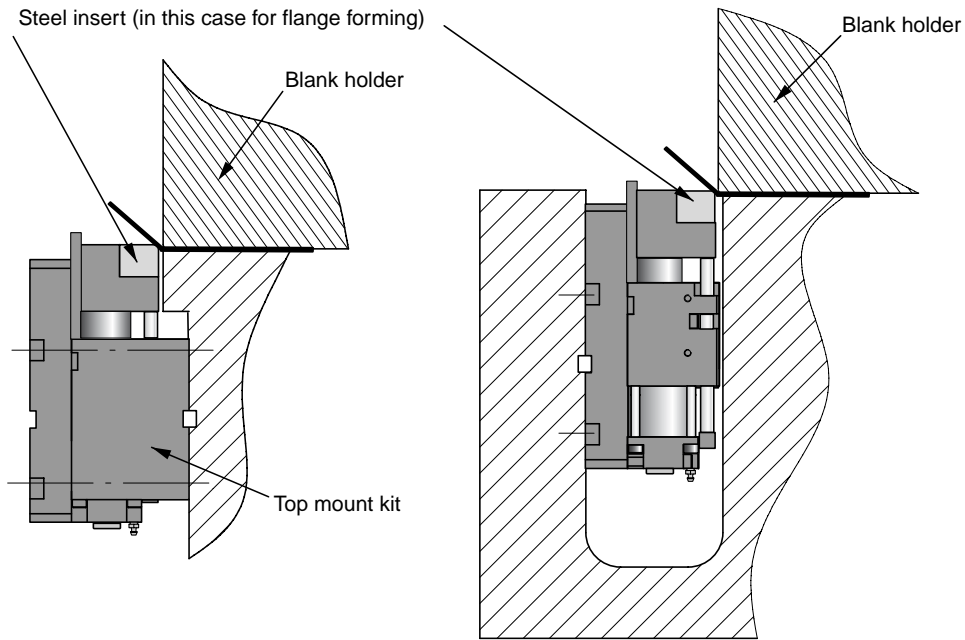

8

Top mount

Base mount

Flange Cam force directions and location

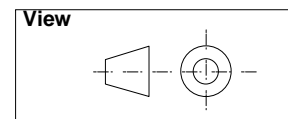
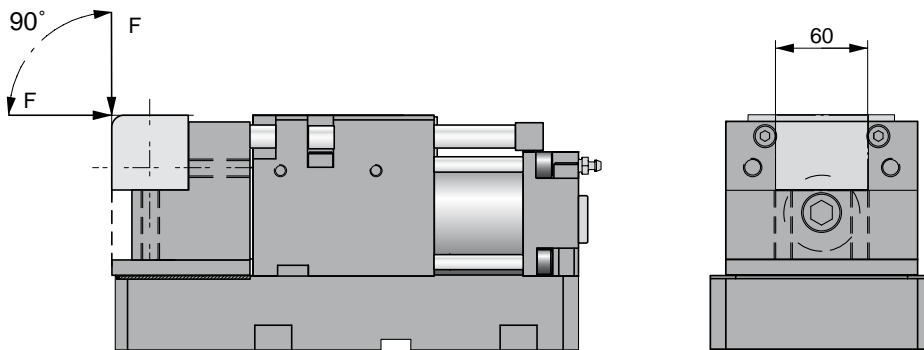

Allowable force directions "F" (within ) created by the flanging operation.

HCF 040 Force Cylinder

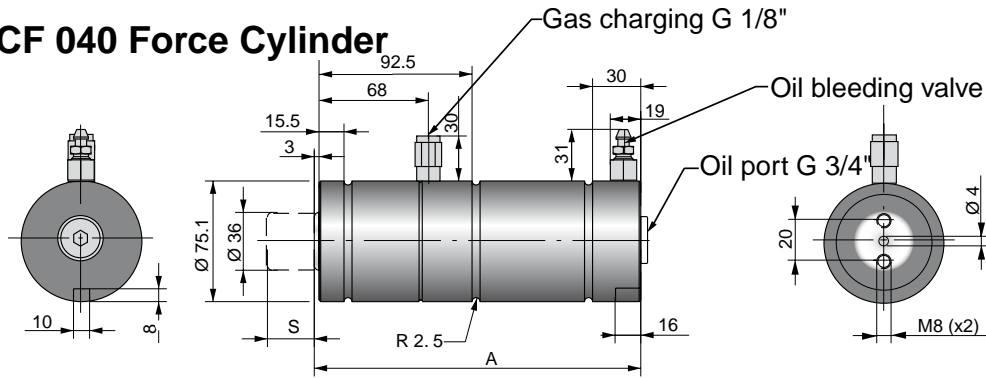

Volvo Part No.	Order No.	Working force* (kN)	Return force* (kN)	Stroke S (mm)	A	Weight (kg)
3054946	HCF 040-025	40	8	25	195	5.5
3054947	HCF 040-050	40	8	50	245	6.5
3054948	HCF 040-100	40	8	100	345	8.6
3054949	HCF 040-150	40	8	150	445	10.7

* = Nominal force for the operation

Flange mount for HCF 040 Order No. FCS-1500 (Mount only)

Volvo Part No. 3044009

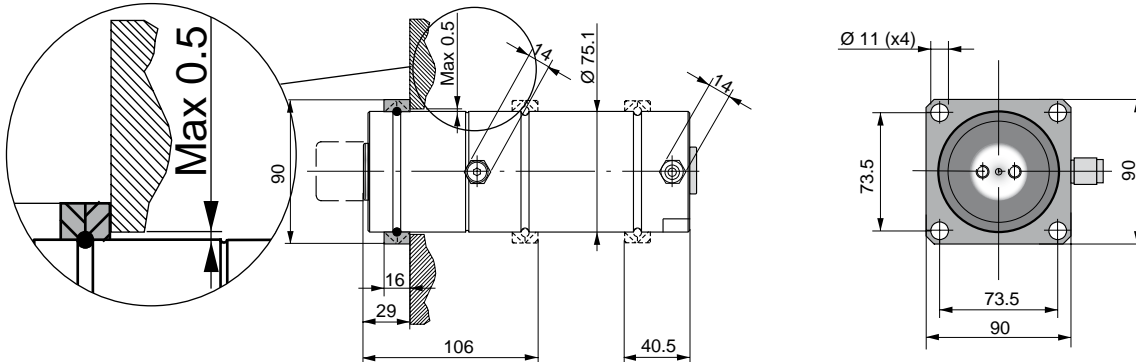

Foot mount for HCF 040 Order No. 3016977-040 (Mounts only)

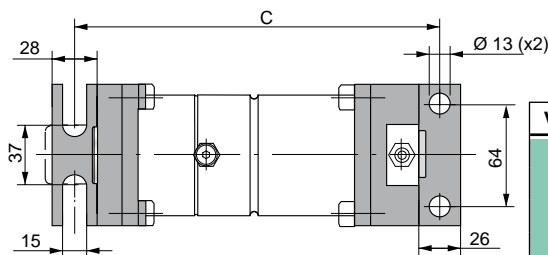
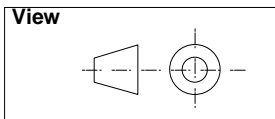
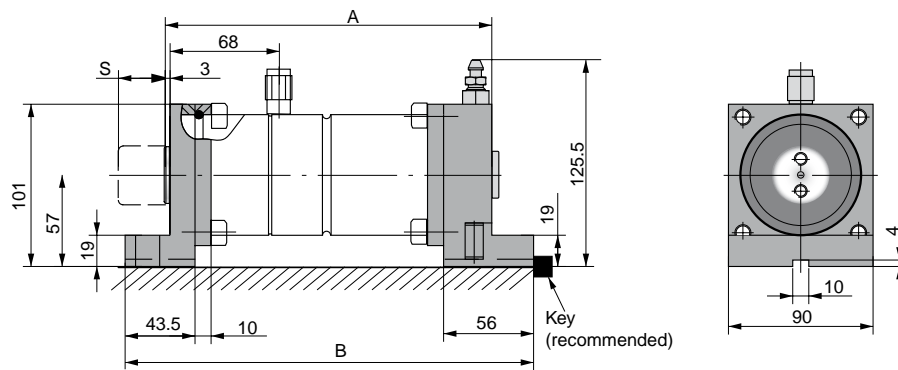

Volvo Part No.	Model	A	B	C
3054950	HCF 040-025	195	246	219
	HCF 040-050	245	296	269
	HCF 040-100	345	396	369
	HCF 040-150	445	496	469

HCF-SP 040

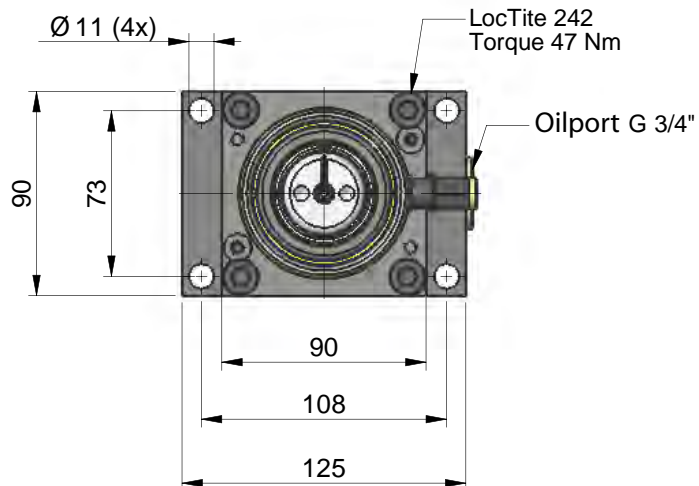
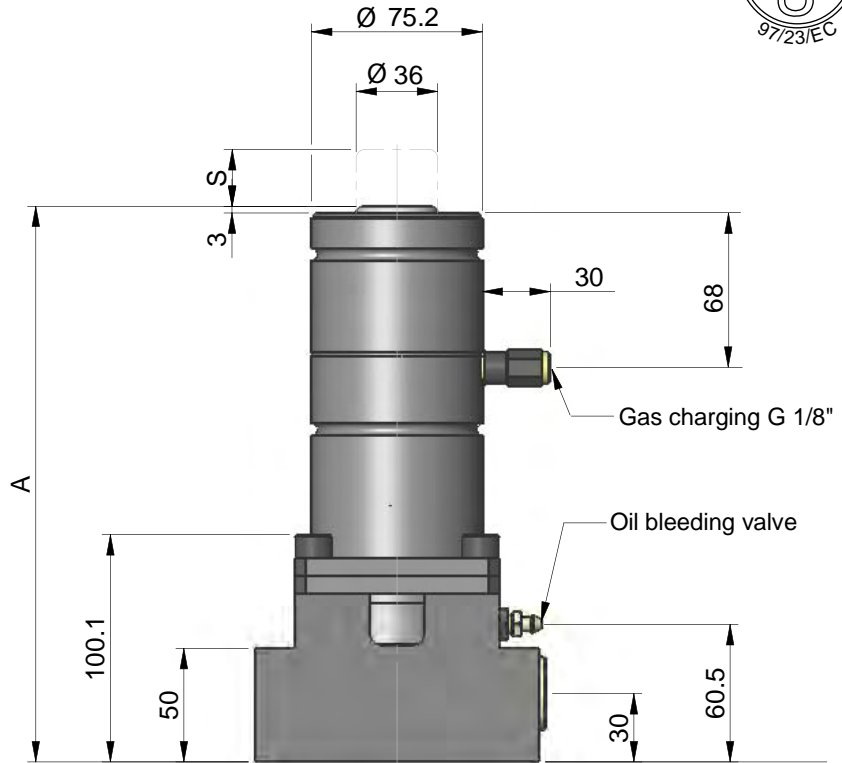
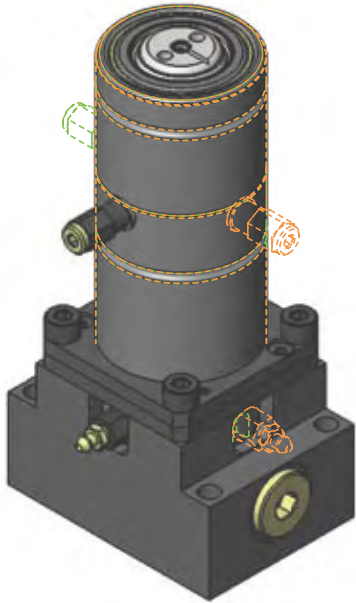

Volvo Part No.	Order No.	Working force* (kN)	Stroke S (mm)	A	Weight [kg]
3054951	HCF-SP 040-025	40	25	245	10.3
3054952	HCF-SP 040-050	40	50	295	11.3
3054953	HCF-SP 040-100	40	100	395	13.4
3054954	HCF-SP 040-150	40	150	495	15.4

*= Nominal force for the operation

HCP 060 Power Unit

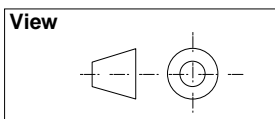
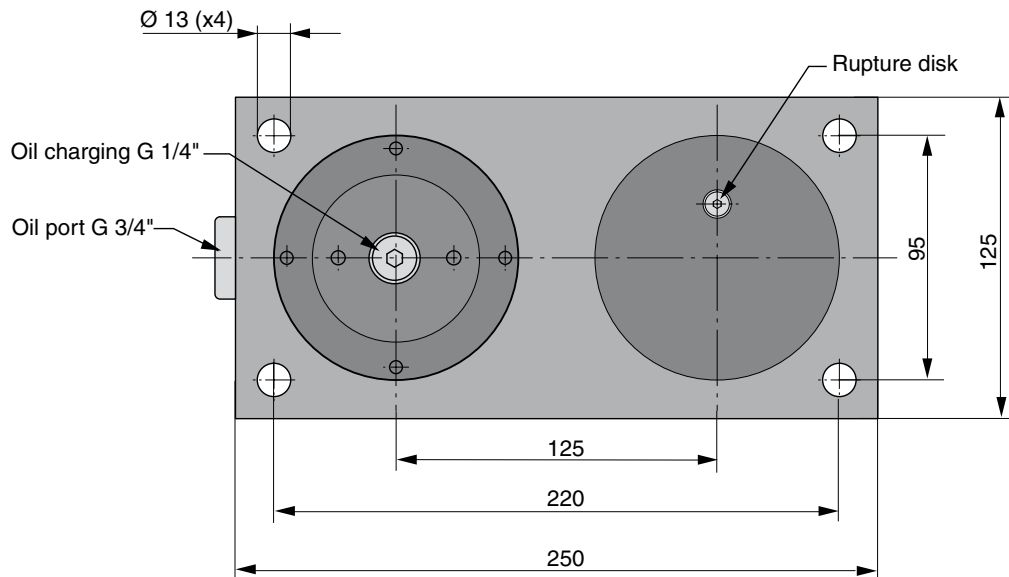
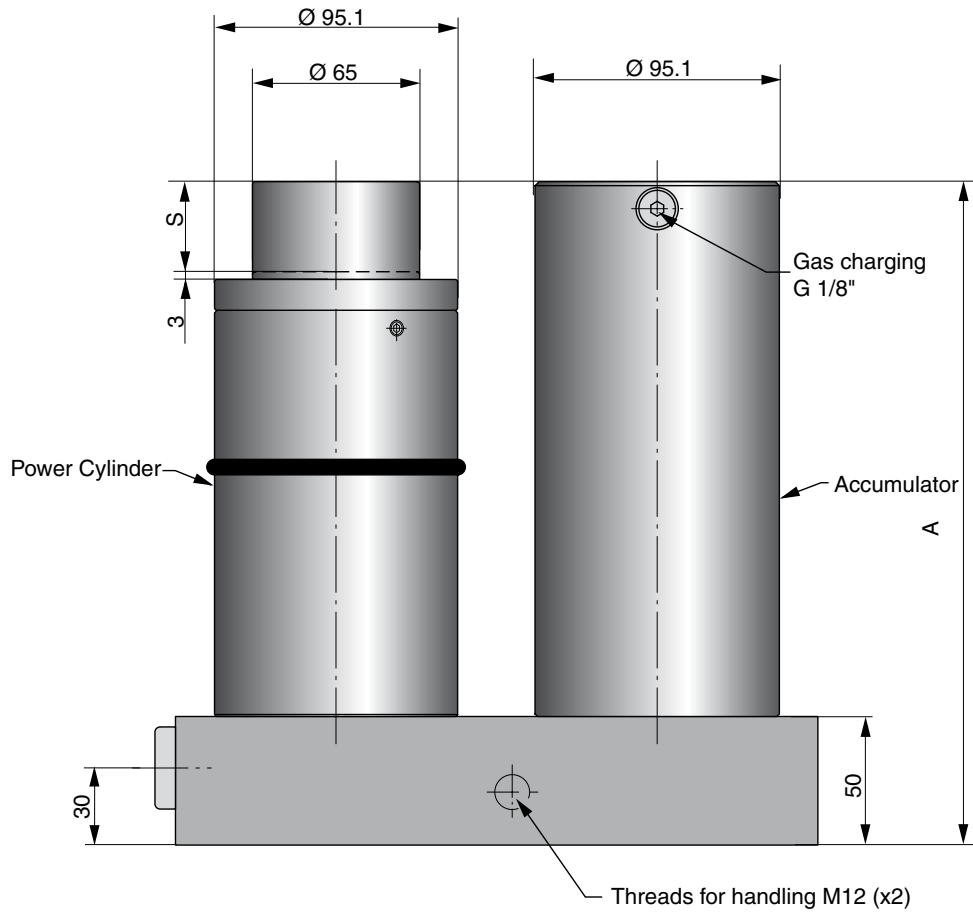

Volvo Part No.	Order No.	Force (kN)	Stroke S (mm)	A	Weight (kg)
3054955	HCP 060-035	60	35	258	26.7
3054956	HCP 060-060	60	60	308	28.4
3054957	HCP 060-110	60	110	408	32.2
3054958	HCP 060-160	60	160	508	35.9

HCP-S 060 Power Unit, with Separate Accumulator

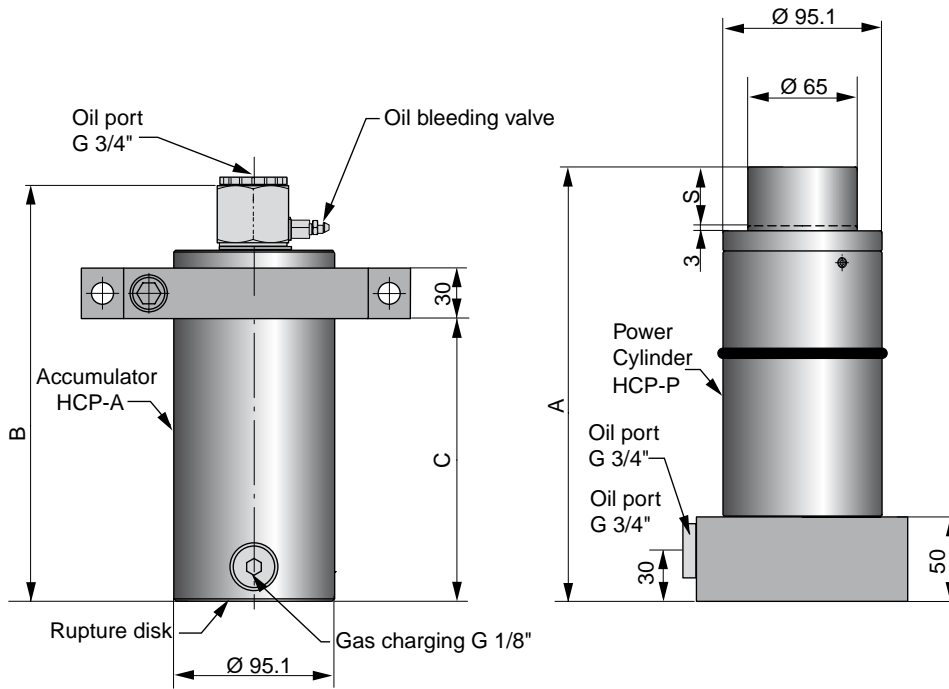

8

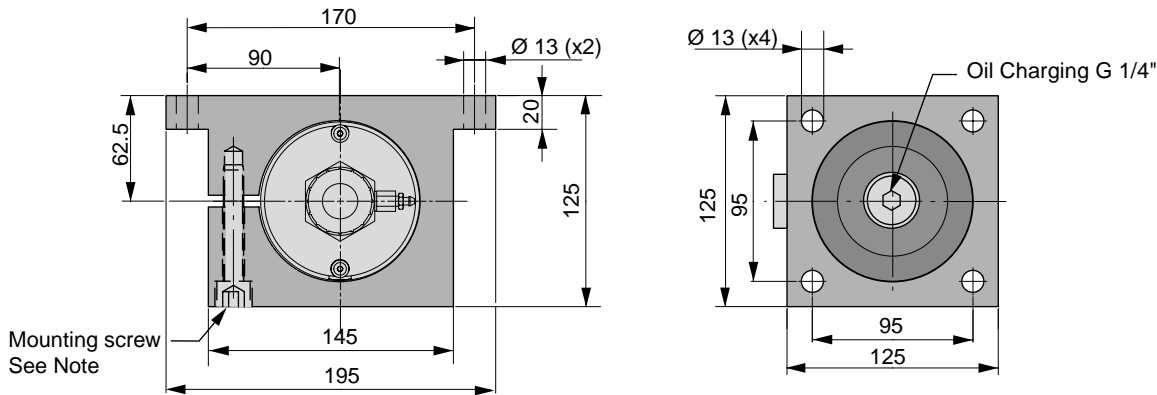

Note! The mounting screw (M12) should be tightened with torque 91Nm

Volvo Part No.	Order No. Complete Power Unit HCP-S	Weight (kg)	Force (kN)	Stroke S (mm)	A	B	C	Volvo Part No.	Order No. Separate Power Cylinder HCP-P	Weight (kg)	Volvo Part No.	Order No. Separate Accumulator HCP-A	Weight (kg)
	HCP-S 060 -035	23.9	60	35	258	235	168	3054959	HCP-P 060 -035	13.9	3054963	HCP-A 060 -035	10.0
	HCP-S 060 -060	25.7	60	60	308	285	218	3054960	HCP-P 060 -060	14.8	3054964	HCP-A 060 -060	10.9
	HCP-S 060 -110	29.4	60	110	408	385	318	3054961	HCP-P 060 -110	16.9	3054965	HCP-A 060 -110	12.5
	HCP-S 060 -160	33.1	60	160	508	485	418	3054962	HCP-P 060 -160	19.0	3054966	HCP-A 060 -160	14.1

Note! The Accumulator should always be used in the system.

CC 060 Compact Cam

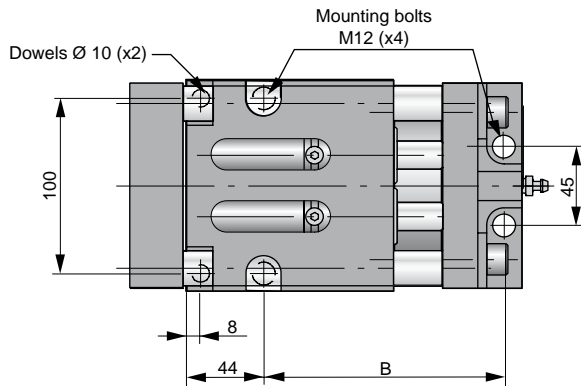
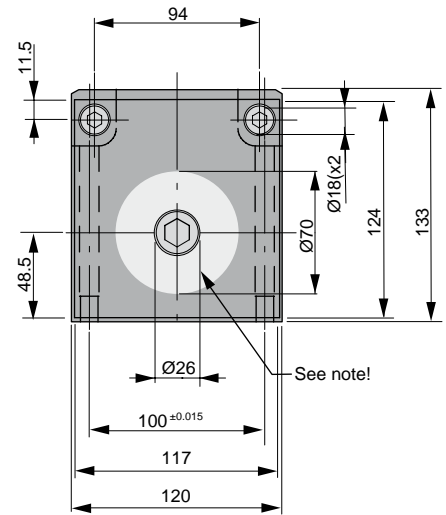
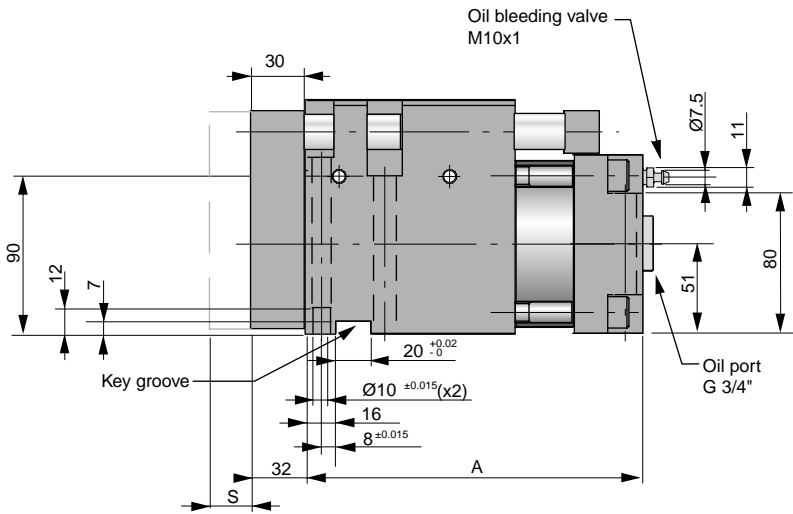

Note!
Important installation information:

We recommend locating the punch in the center of the piston rod, but it is also possible to locate the force which the punch will create in the operations within the area marked .

When piercing an opened hole or cutting an edge we recommend that extra guiding is used to prevent the unit against sideload.

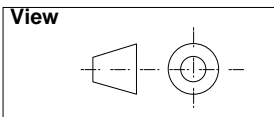



Volvo Part No.	Order No.	Working force* (kN)	Return force (kN)	Stroke S (mm)	A	B	Weight (kg)
3054967	CC 060-024	60	7	24	191	137	22.3
3054968	CC 060-049	60	7	49	216	162	23.4
3054969	CC 060-099	60	7	99	266	212	26.0

* Nominal force available for the operation

CC-H 060 Compact Cam for pressure control

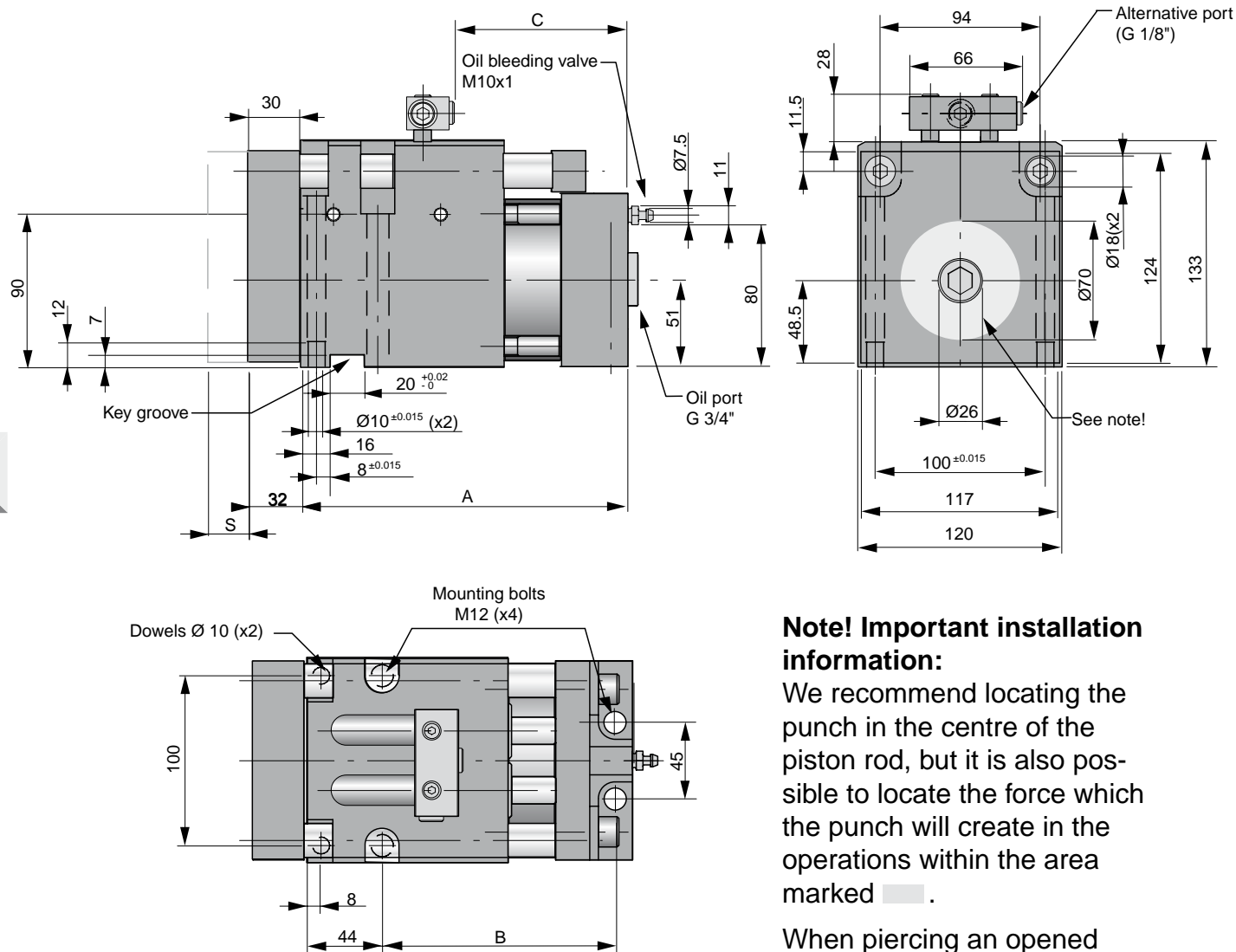
This version can only be used together with a hose system as there are no gas charging valve in the springs or adapters

**Note! Important installation information:**

We recommend locating the punch in the centre of the piston rod, but it is also possible to locate the force which the punch will create in the operations within the area marked .

When piercing an opened hole or cutting an edge we recommend that extra guiding is used to prevent the unit against sideload.

Volvo Part No.	Order No.	Working force* (kN)	Return force (kN)	Stroke S (mm)	A	B	C	Weight (kg)
	CC-H 060-024	60	7	24	191	137	103	22.5
	CC-H 060-049	60	7	49	216	162	153	23.6
	CC-H 060-099	60	7	99	266	212	228	26.2

* = Nominal force available for the operation

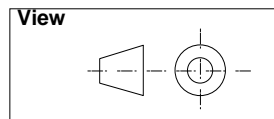

HCF 060 Force Cylinder

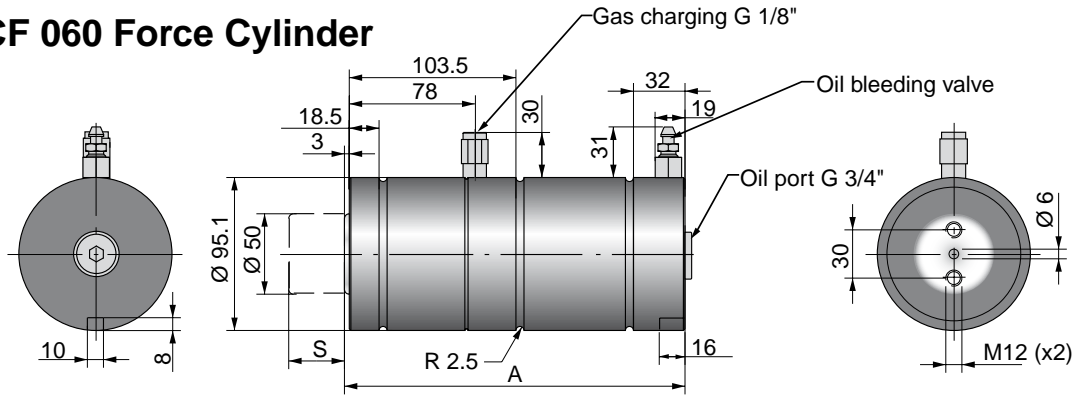

Volvo Part No.	Order No.	Working force* (kN)	Return force (kN)	Stroke S (mm)	A	Weight (kg)
3054970	HCF 060-025	60	6	25	211	9.8
3054971	HCF 060-050	60	6	50	261	11.6
3054972	HCF 060-100	60	6	100	361	15.1
3054973	HCF 060-150	60	6	150	461	18.6

* = Nominal force available for the operation

Flange mount for HCF 060 Order No. FCS-3000 (Mount only) Volvo Part No. 3044017

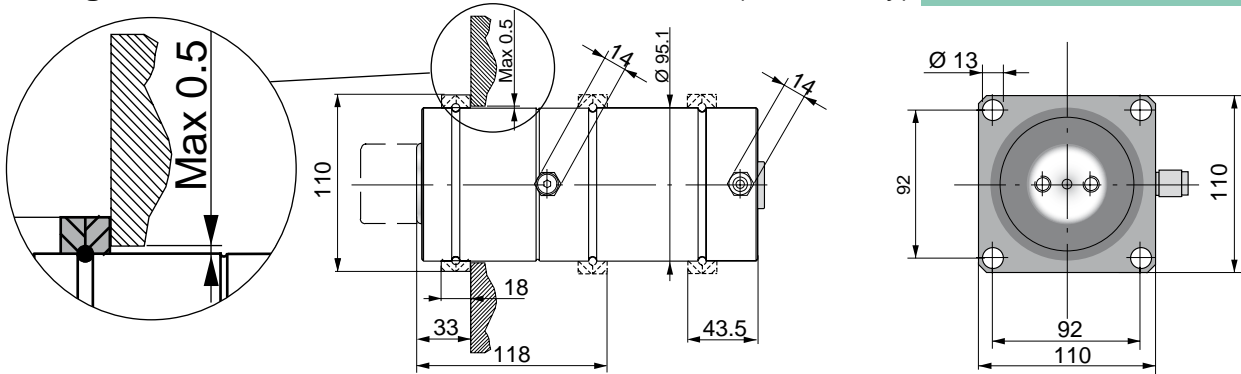

Foot mount for HCF 060 Order No. 3016977-060 (Mounts only)

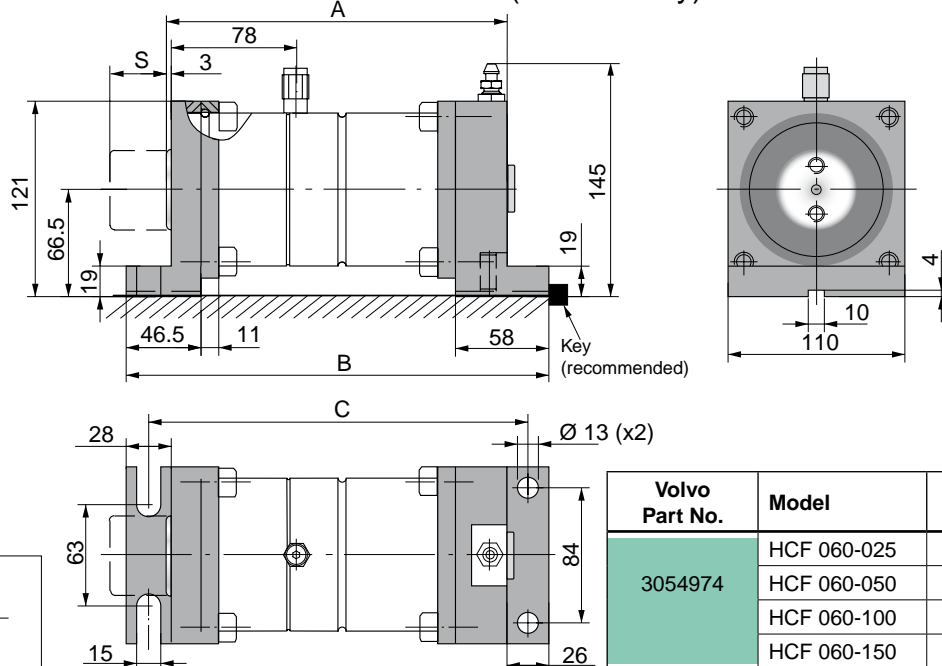

Volvo Part No.	Model	A	B	C
3054974	HCF 060-025	211	262	235
	HCF 060-050	261	312	285
	HCF 060-100	361	412	385
	HCF 060-150	461	512	485

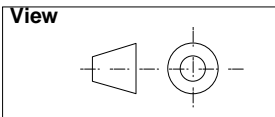

HCF-SP 060

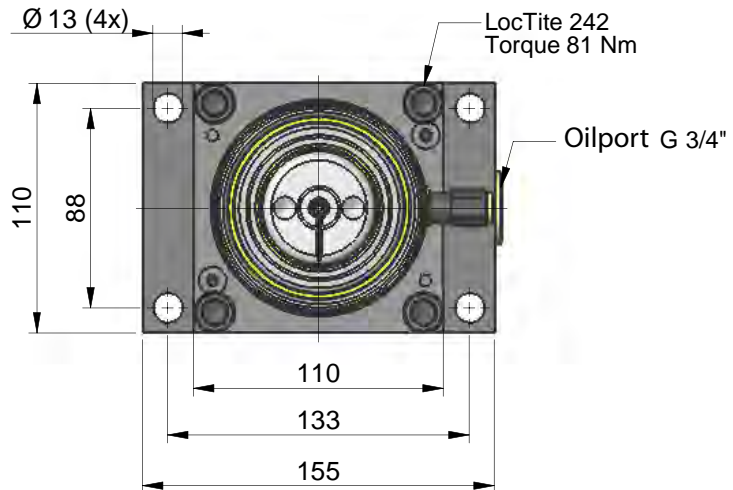
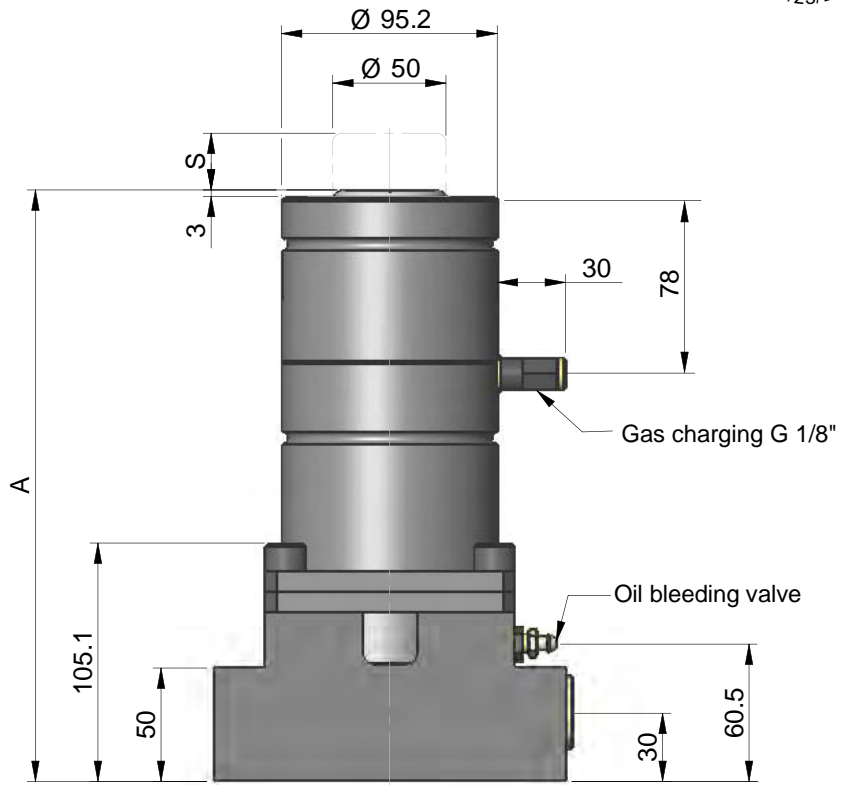
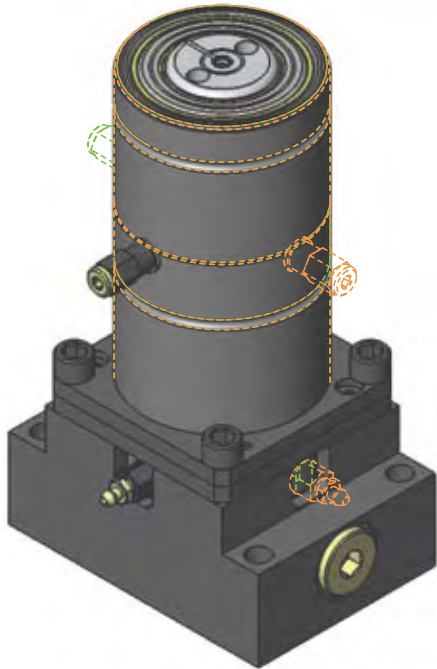

Volvo Part No.	Order No.	Working force* (kN)	Stroke S (mm)	A	Weight [kg]
3054975	HCF-SP 060-025	60	25	261	17.4
3054976	HCF-SP 060-050	60	50	361	19.2
3054977	HCF-SP 060-100	60	100	511	22.7
3054978	HCF-SP 040-150	60	150	661	26.2

*= Nominal force for the operation

HCP 090 Power Unit

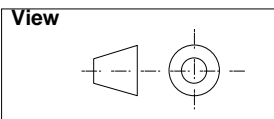
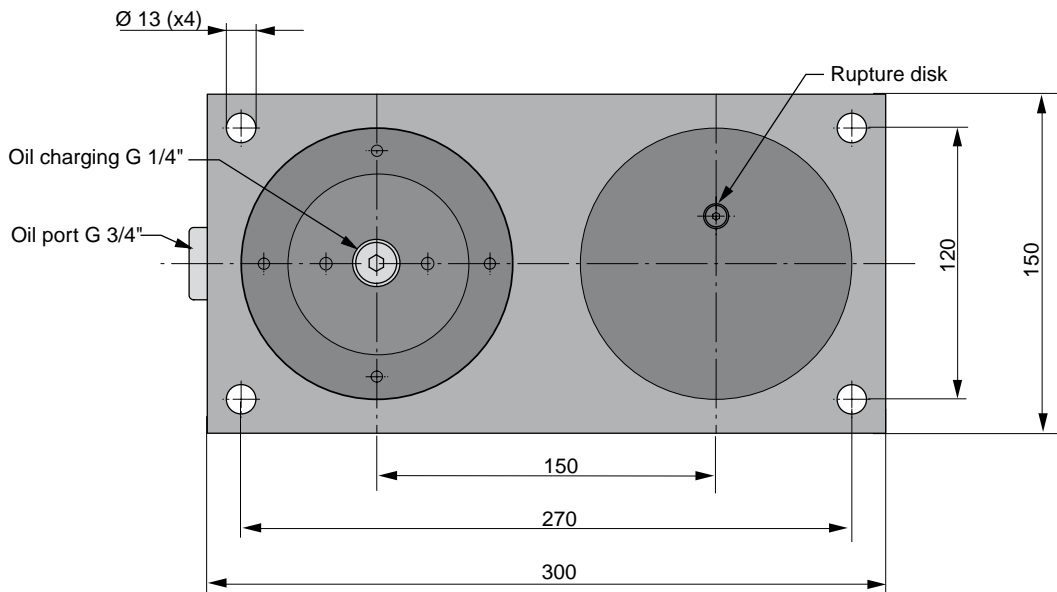
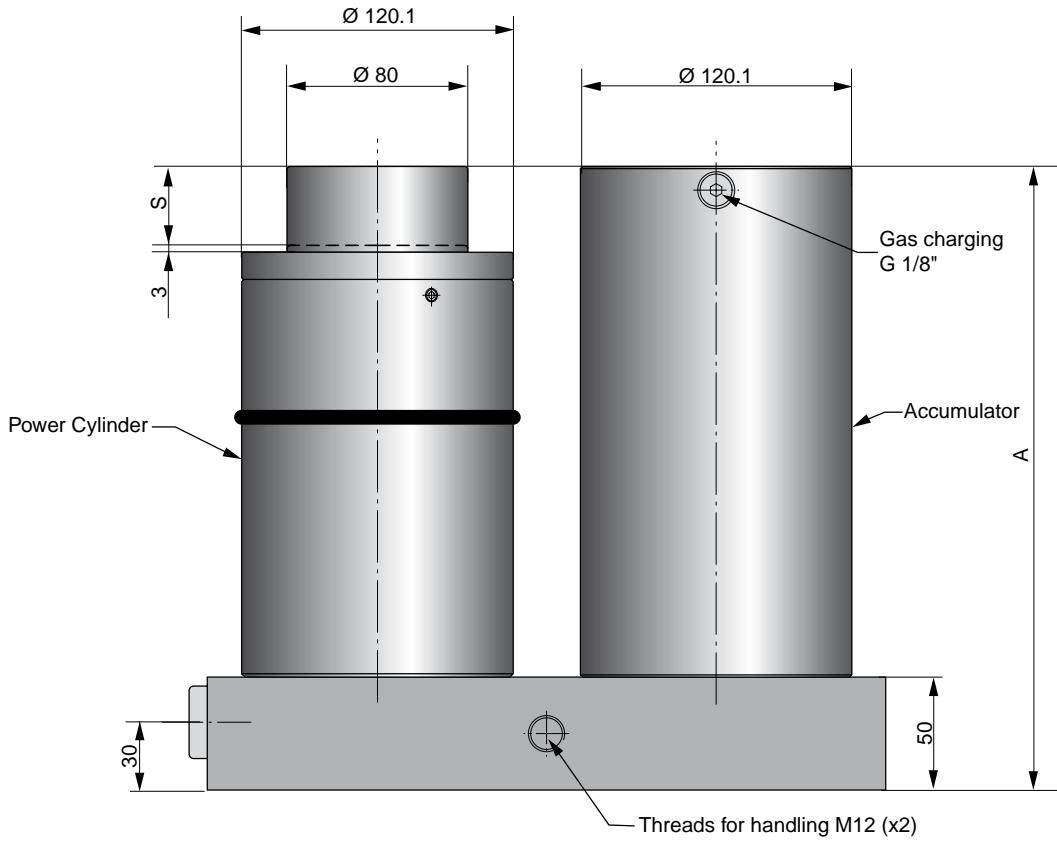

Volvo Part No.	Order No.	Force (kN)	Stroke S (mm)	A	Weight (kg)
3054979	HCP 090-035	90	35	276	43.1
3054980	HCP 090-060	90	60	326	46.1
3054981	HCP 090-110	90	110	426	52.1
3054982	HCP 090-160	90	160	526	52.8

HCP-S 090 Power Unit, with Separate Accumulator

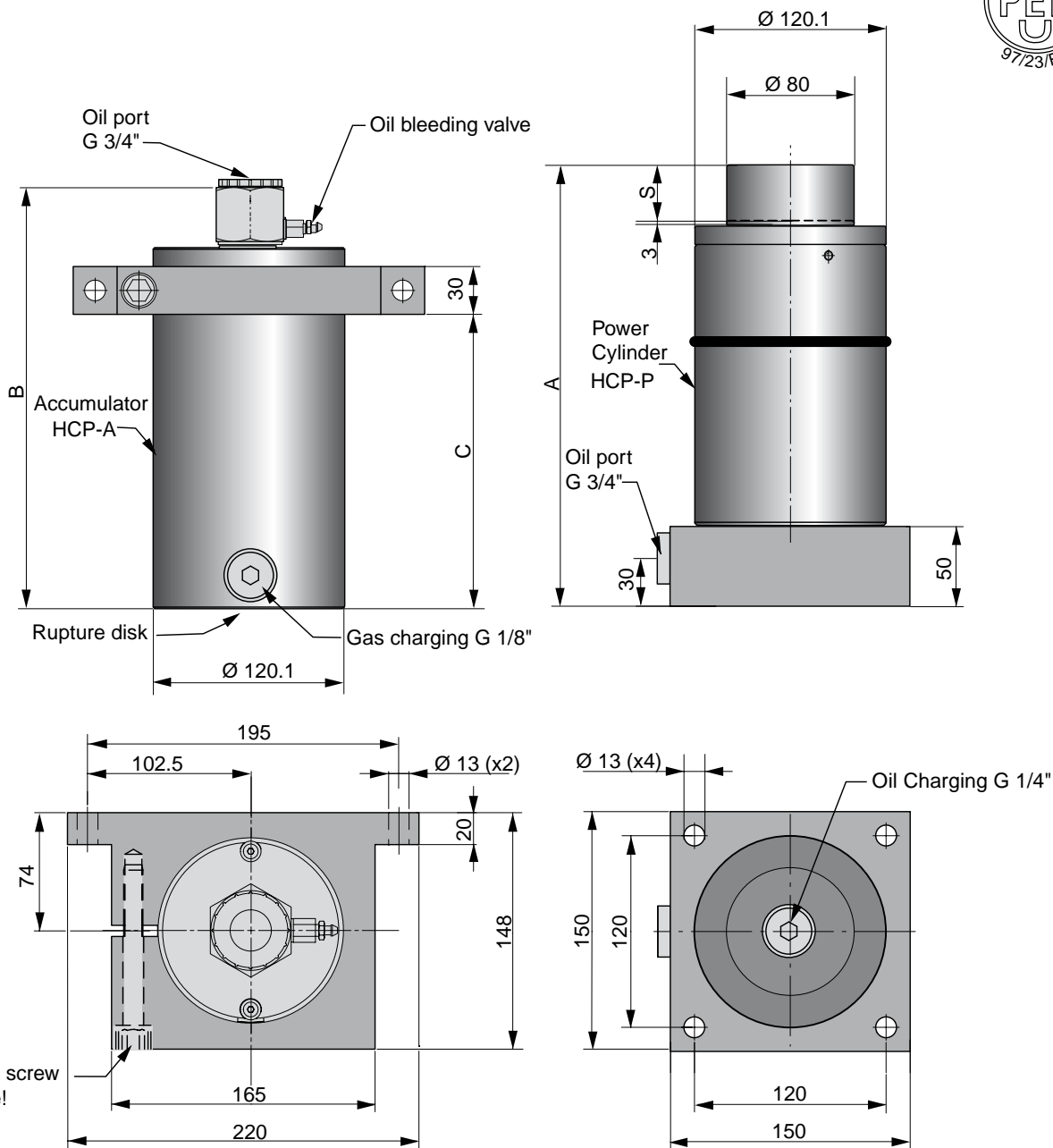

8

Note! The mounting screw (M12) should be tightened with torque 91Nm

Volvo Part No.	Order No. Complete Power Unit HCP-S	Weight (kg)	Force (kN)	Stroke S (mm)	A	B	C	Volvo Part No.	Order No. Separate Power Cylinder HCP-P	Weight (kg)	Volvo Part No.	Order No. Separate Accumulator HCP-A	Weight (kg)
	HCP-S 090-035	38.3	90	35	276	265	186	3054983	HCP-P 090-035	22.6	3054987	HCP-A 090-035	15.7
	HCP-S 090-060	41.2	90	60	326	315	236	3054984	HCP-P 090-060	24.2	3054988	HCP-A 090-060	17.0
	HCP-S 090-110	47.3	90	110	426	415	336	3054985	HCP-P 090-110	27.5	3054989	HCP-A 090-110	19.8
	HCP-S 090-160	53.3	90	160	526	514	436	3054986	HCP-P 090-160	30.8	3054990	HCP-A 090-160	22.5

Note! The Accumulator should always be used in the system.

CC 090 Compact Cam

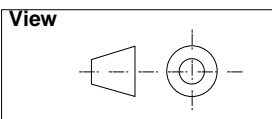
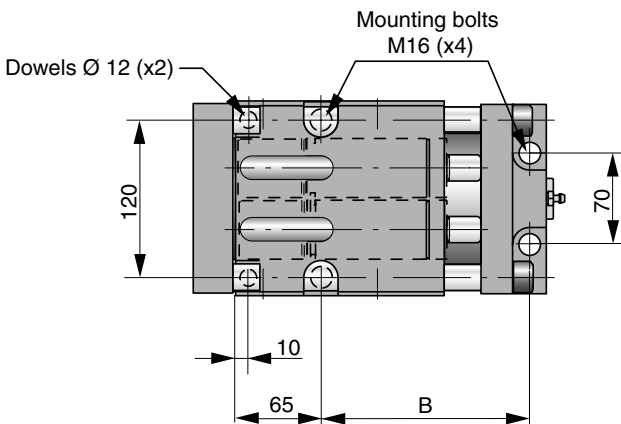
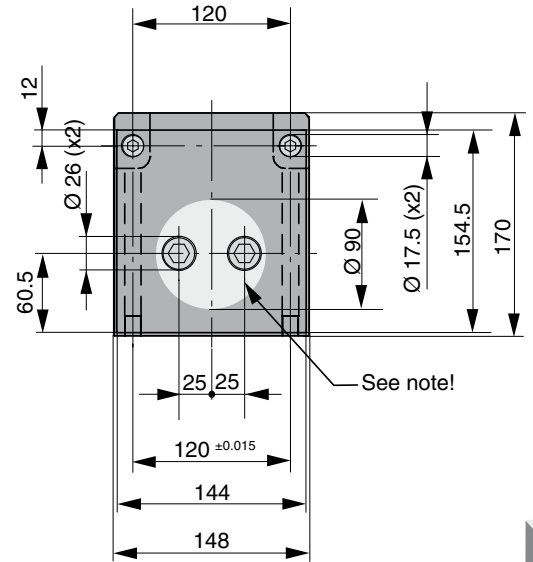
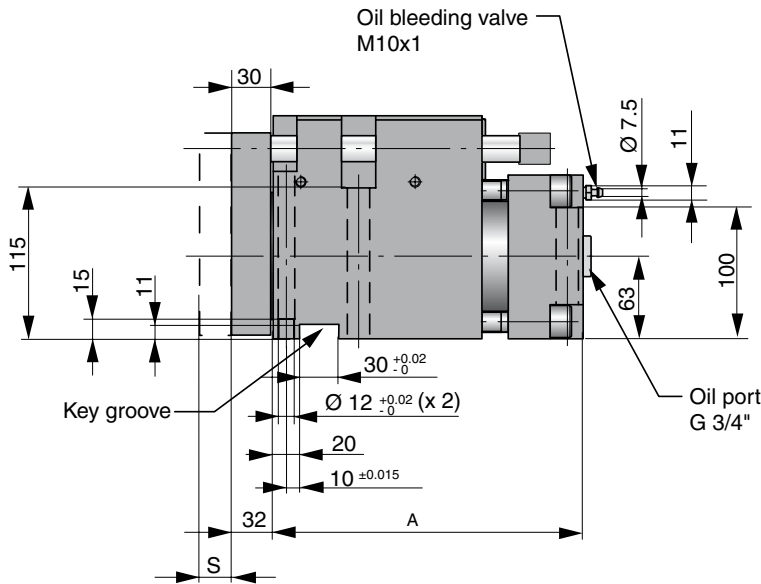

Note! Important installation information:

We recommend locating the punch in the centre of the piston rod, but it is also possible to locate the force which the punch will create in the operations within the area marked .

When piercing an opened hole or cutting an edge we recommend that extra guiding is used to prevent the unit against sideload.

Volvo Part No.	Order No.	Working force* (kN)	Return force (kN)	Stroke S (mm)	A	B	Weight (kg)
3054991	CC 090-024	90	18	24	236	159	33.5
3054992	CC 090-049	90	18	49	261	184	39.7
3054993	CC 090-099	90	18	99	311	234	44.9

* = Nominal force available for the operation

CC-H 090 Compact Cam for pressure control



This version can only be used together with a hose system as there are no gas charging valves in the springs or adapters

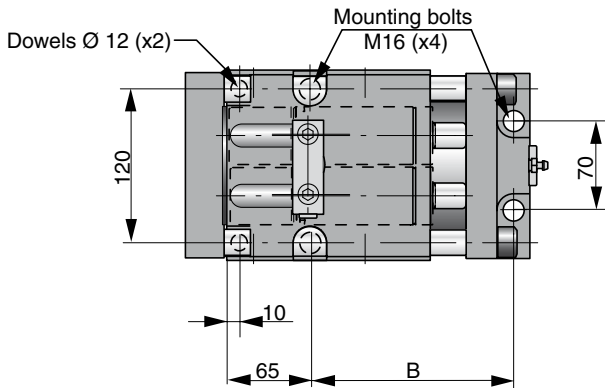
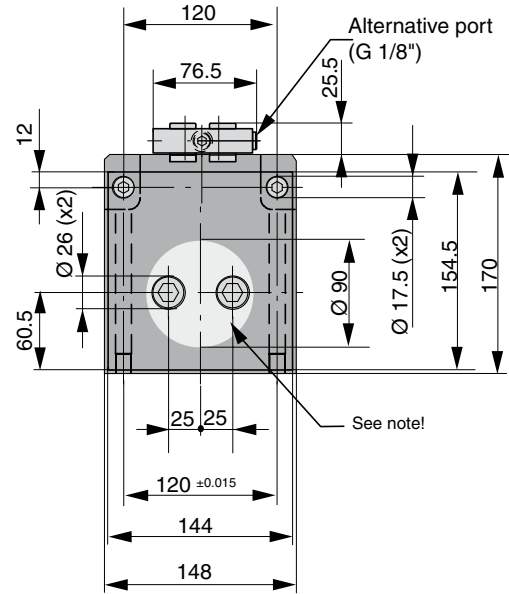
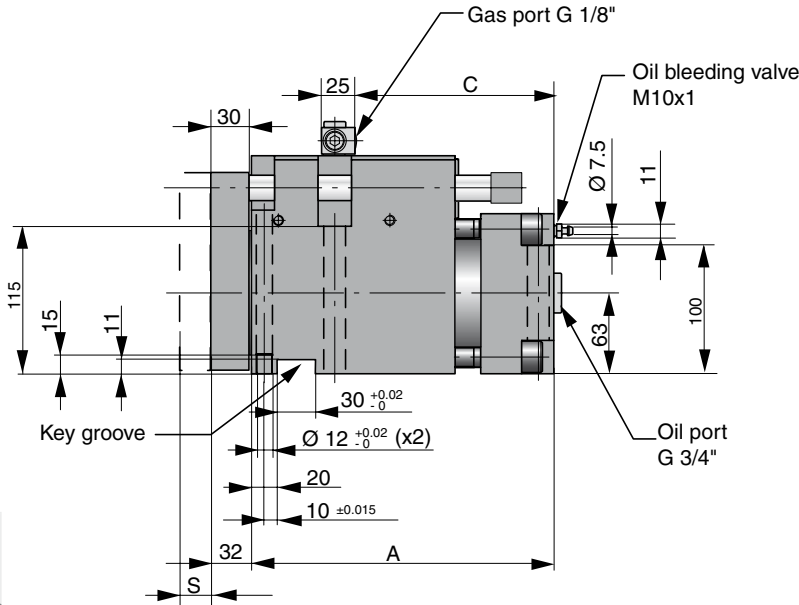

Note! There are two G1/8" gas ports which can be used to couple to a hose system. Use only one of these to connect the hose system, the other should remain plugged.

Note!
Important installation information:

We recommend locating the punch in the centre of the piston rod, but it is also possible to locate the force which the punch will create in the operations within the area marked .

When piercing an opened hole or cutting an edge we recommend that extra guiding is used to prevent the unit against sideload.

Volvo Part No.	Order No.	Working force* (kN)	Return force (kN)	Stroke S (mm)	A	B	C	Weight (kg)
	CC-H 090-024	90	18	24	236	159	158	33.7
	CC-H 090-049	90	18	49	261	184	208	39.7
	CC-H 090-099	90	18	99	311	234	283	44.9

* = Nominal force available for the operation

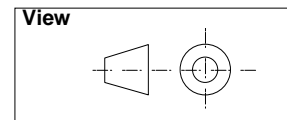

HCF 090 Force Cylinder

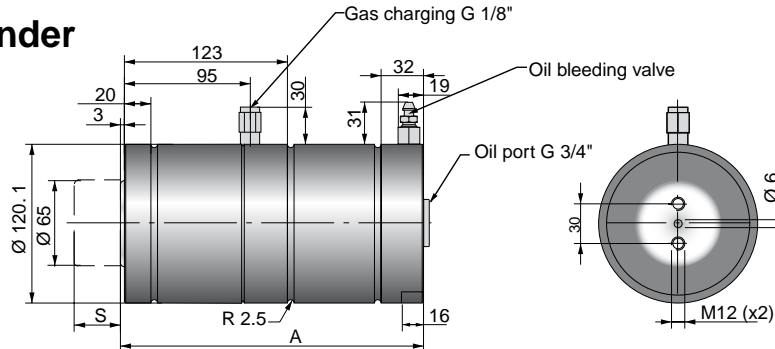
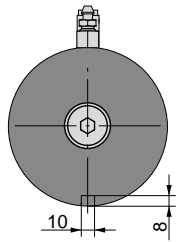

Volvo Part No.	Order No.	Working force* (kN)	Return force* (kN)	Stroke S (mm)	A	Weight (kg)
3054994	HCF 090-025	90	18	25	229	15.8
3054995	HCF 090-050	90	18	50	279	18.7
3054996	HCF 090-100	90	18	100	379	24.5
3054997	HCF 090-150	90	18	150	479	30.3

* = Nominal force for the operation

Flange mount for HCF 090 Order No. FCS-5000 (Mount only) Volvo Part No. 3044692

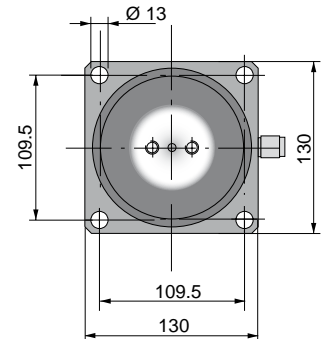
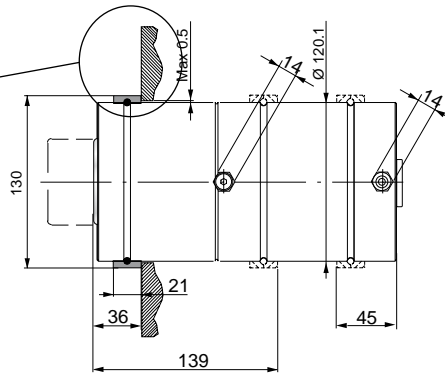
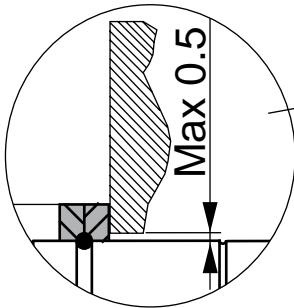

Foot mount for HCF 090 Order No. 3016977-090 (Mounts only)

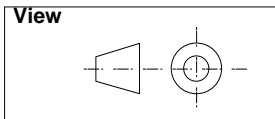
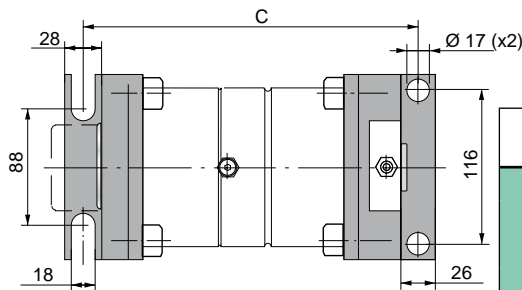
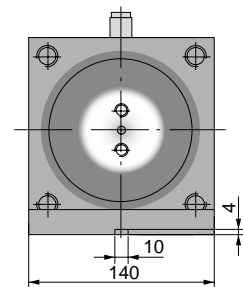
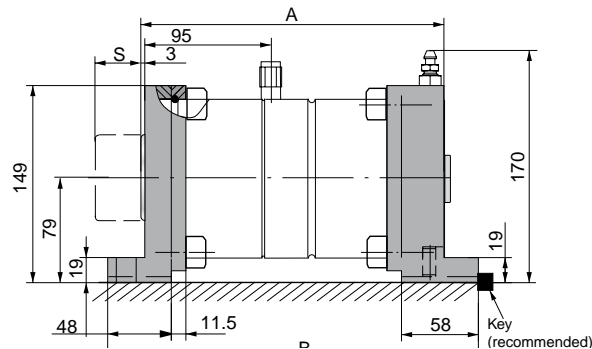

Volvo Part No.	Model	A	B	C
3054999	HCF 090-025	229	280	254
	HCF 090-050	279	330	304
	HCF 090-100	379	430	404
	HCF 090-150	479	530	504

HCF-SP 090

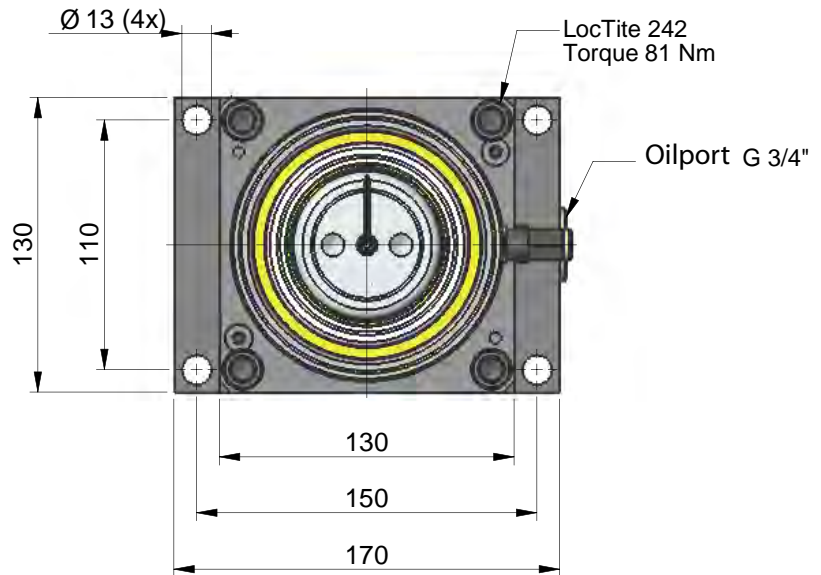
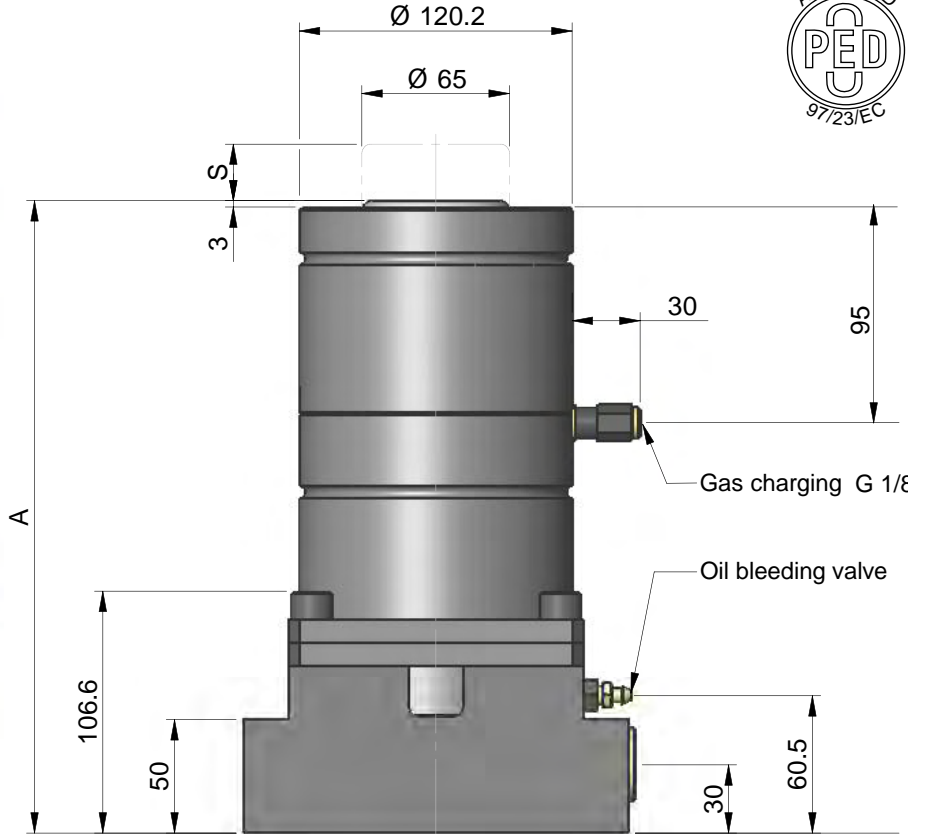
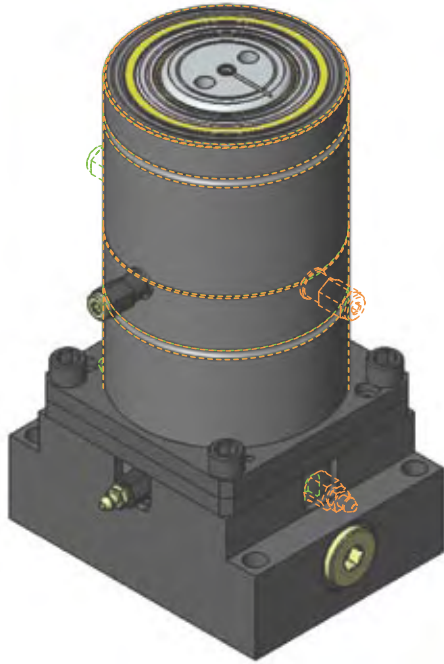

Volvo Part No.	Order No.	Working force* (kN)	Stroke S (mm)	A	Weight [kg]
3055000	HCF-SP 090-025	90	25	279	28
3055001	HCF-SP 090-050	90	50	329	30.9
3055002	HCF-SP 090-100	90	100	429	36.8
3055003	HCF-SP 090-150	90	150	529	42.6

*= Nominal force for the operation

HCP 150 Power Unit

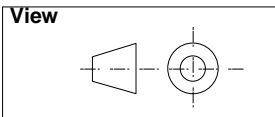
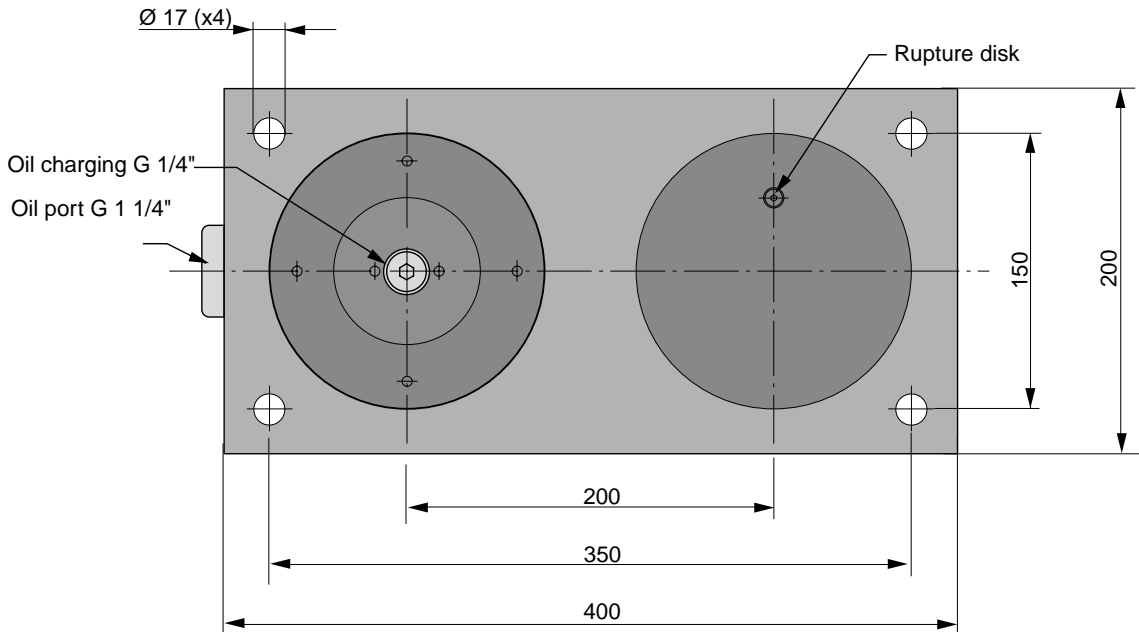
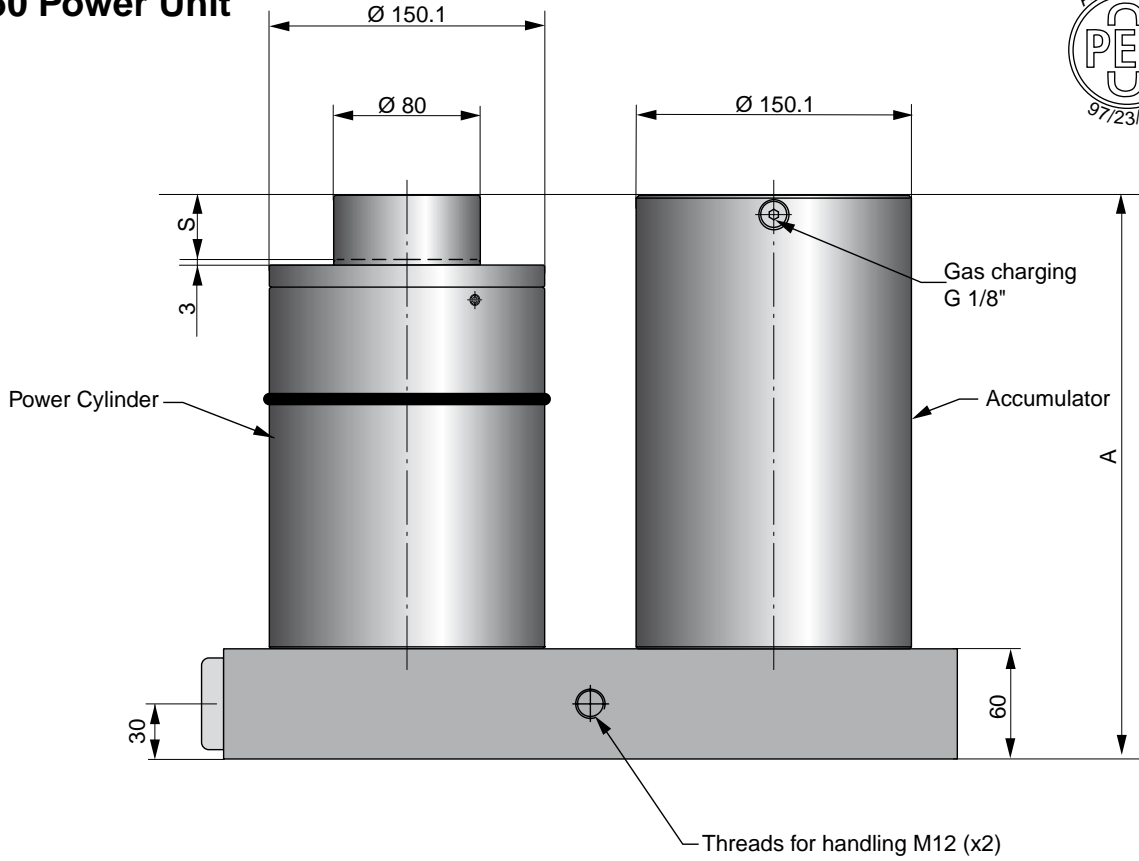

Volvo Part No.	Order No.	Force (kN)	Stroke (mm)	A	Weight (kg)
3055004	HCP 150-035	150	35	307	83.1
3055005	HCP 150-060	150	60	357	87.7
3055006	HCP 150-110	150	110	457	97.0
3055007	HCP 150-160	150	160	557	106.3

HCP-S 150 Power Unit, with Separate Accumulator

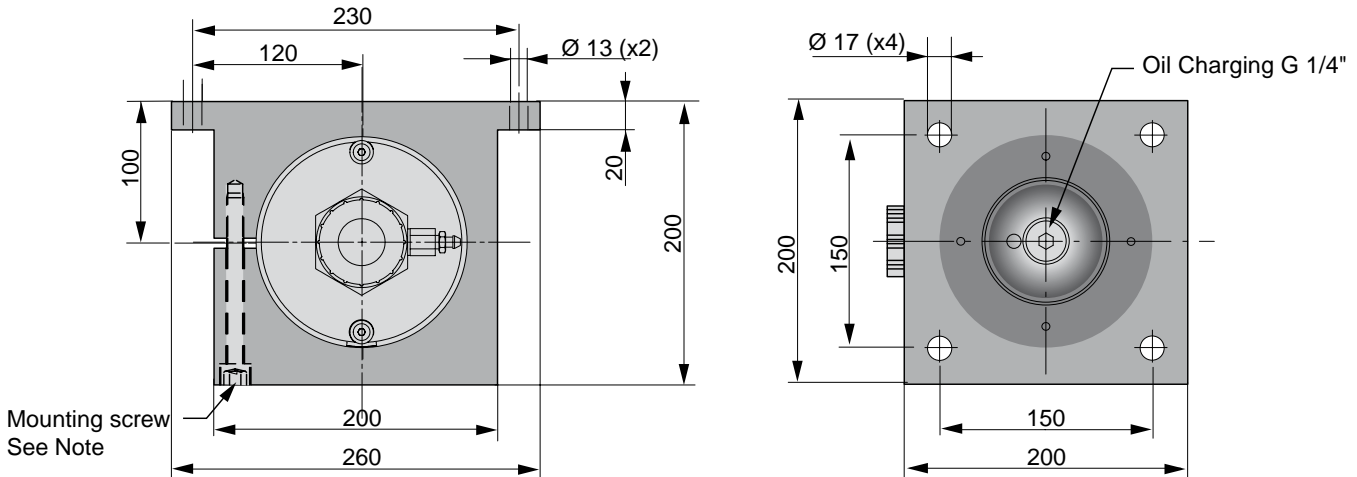
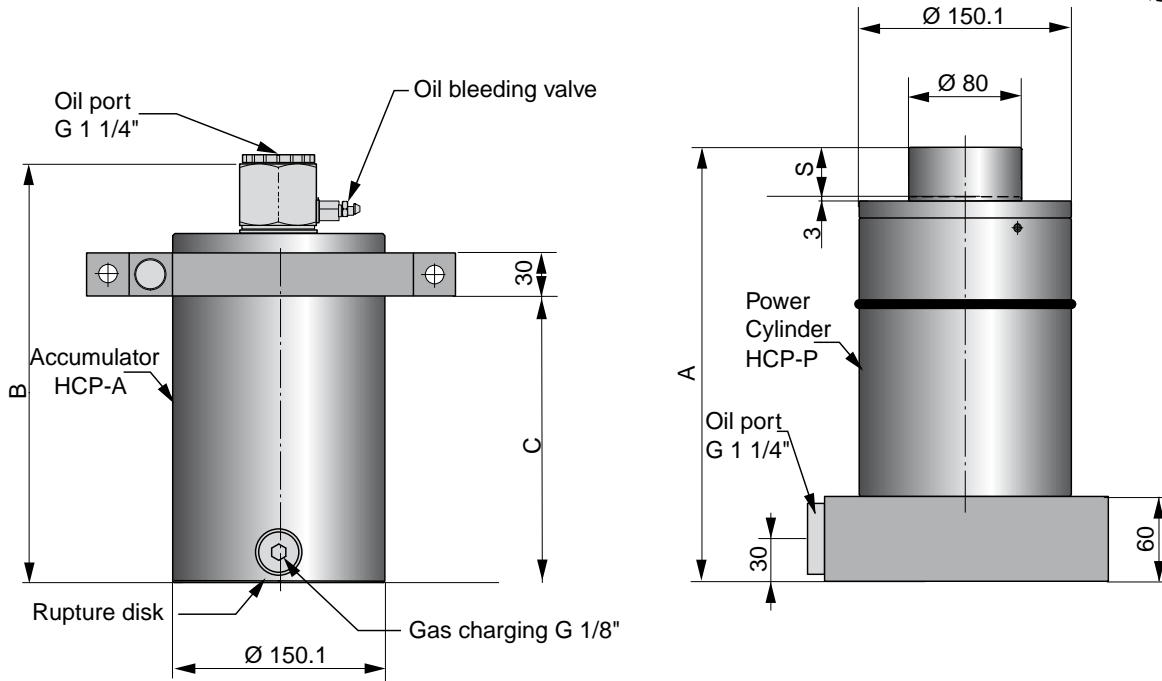

Note! The mounting screw (M12) should be tightened with torque 91Nm

Volvo Part No.	Order No. Complete Power Unit HCP-S	Weight (kg)	Force (kN)	Stroke S (mm)	A	B	C	Volvo Part No.	Order No. Separate Power Cylinder HCP-P	Weight (kg)	Volvo Part No.	Order No. Separate Accumulator HCP-A	Weight (kg)
	HCP-S 150-035	71.1	90	35	307	294	207	3055008	HCP-P 150-035	43.6	3055012	HCP-A 150-035	27.7
	HCP-S 150-060	75.5	90	60	357	344	257	3055009	HCP-P 150-060	45.9	3055013	HCP-A 150-060	29.8
	HCP-S 150-110	85.0	90	110	457	444	357	3055010	HCP-P 150-110	50.9	3055014	HCP-A 150-110	34.1
	HCP-S 150-160	94.3	90	160	557	544	457	3055011	HCP-P 150-160	55.9	3055015	HCP-A 150-160	38.4

Note! The Accumulator should always be used in the system.

CC 150 Compact Cam

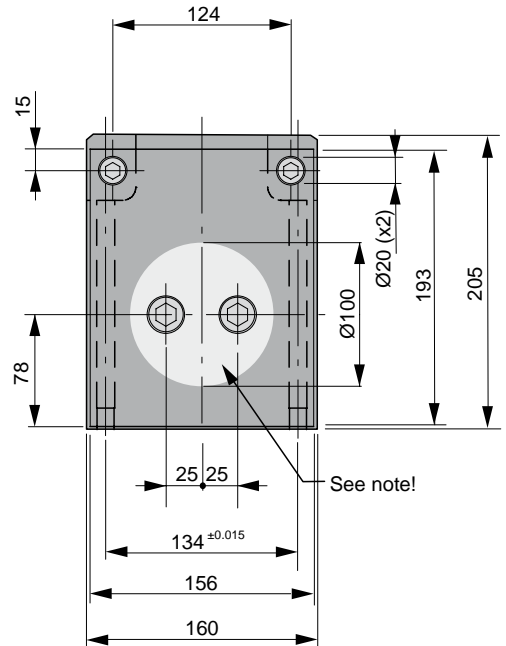
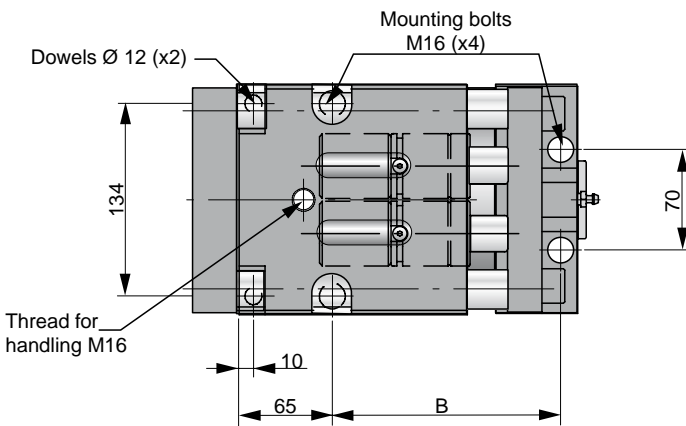
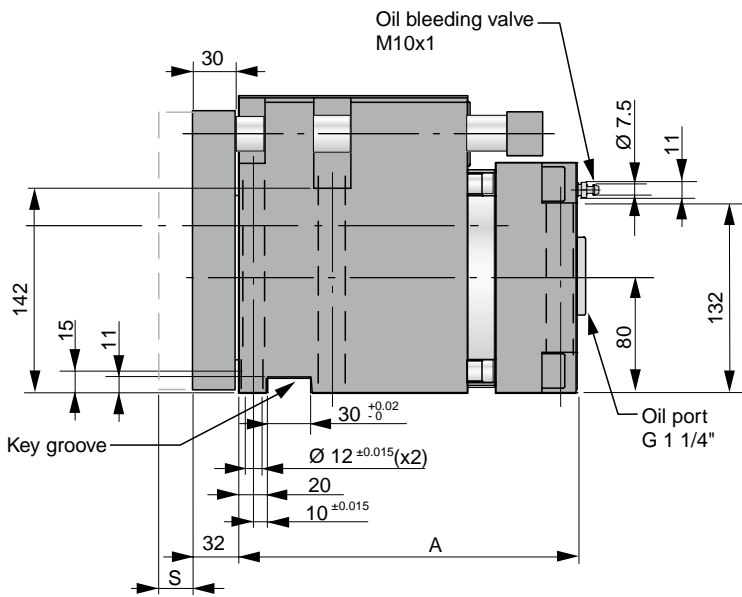

Note!
Important installation information:

We recommend locating the punch in the centre of the piston rod, but it is also possible to locate the force which the punch will create in the operations within the area marked .

When piercing an opened hole or cutting an edge we recommend that extra guiding is used to prevent the unit against sload.

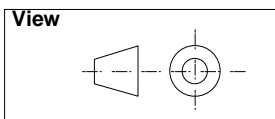

Volvo Part No.	Order No.	Working force* (kN)	Return force (kN)	Stroke S (mm)	A	B	Weight (kg)
3055016	CC 150-024	150	15	24	236	159	57.7
3055017	CC 150-049	150	15	49	261	184	60.0
3055018	CC 150-099	150	15	99	311	234	65.6

* = Nominal force available for the operation

CC-H 150 Compact Cam for pressure control

This version can only be used together with a hose system as there are no gas charging valves in the springs or adapters

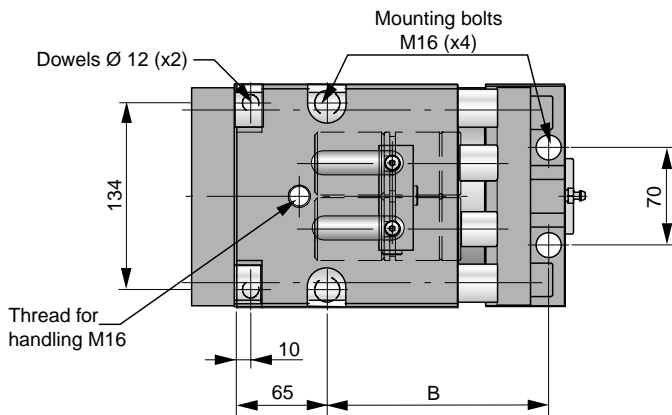
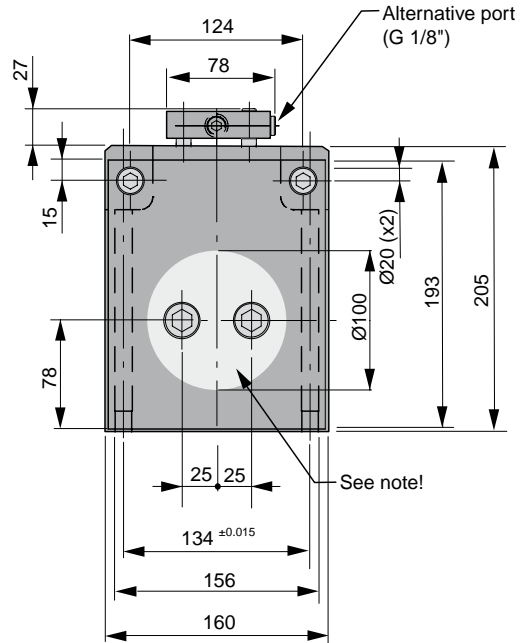
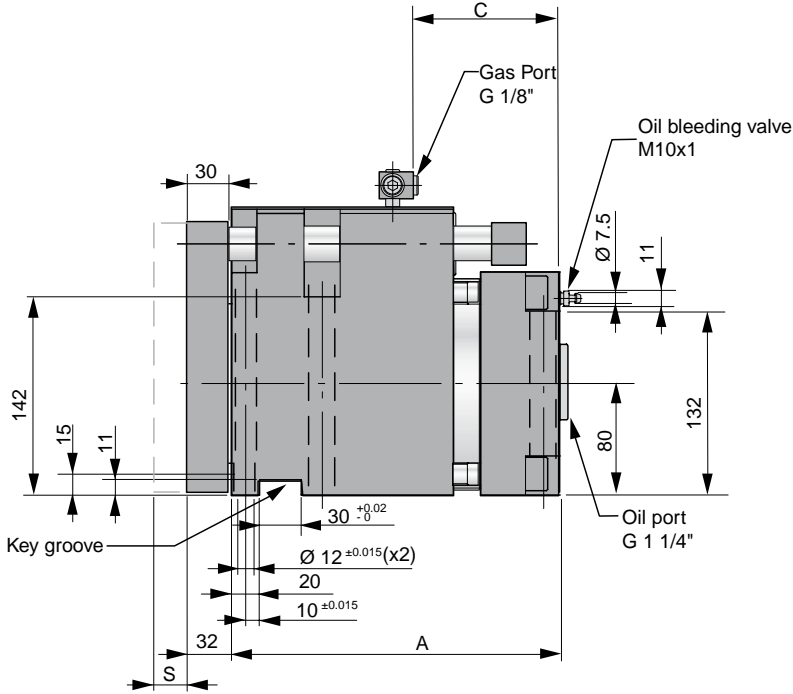

Note!
Important installation information:

We recommend locating the punch in the centre of the piston rod, but it is also possible to locate the force which the punch will create in the operations within the area marked .

When piercing an opened hole or cutting an edge we recommend that extra guiding is used to prevent the unit against sload.

Volvo Part No.	Order No.	Working force* (kN)	Return force (kN)	Stroke S (mm)	A	B	C	Weight (kg)
	CC-H 150-024	150	15	24	236	159	109	57.9
	CC-H 150-049	150	15	49	261	184	159	60.2
	CC-H 150-099	150	15	99	311	234	234	65.8

* = Nominal force available for the operation

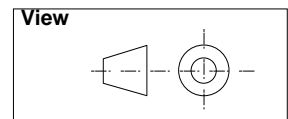

HCF 150 Force Cylinder

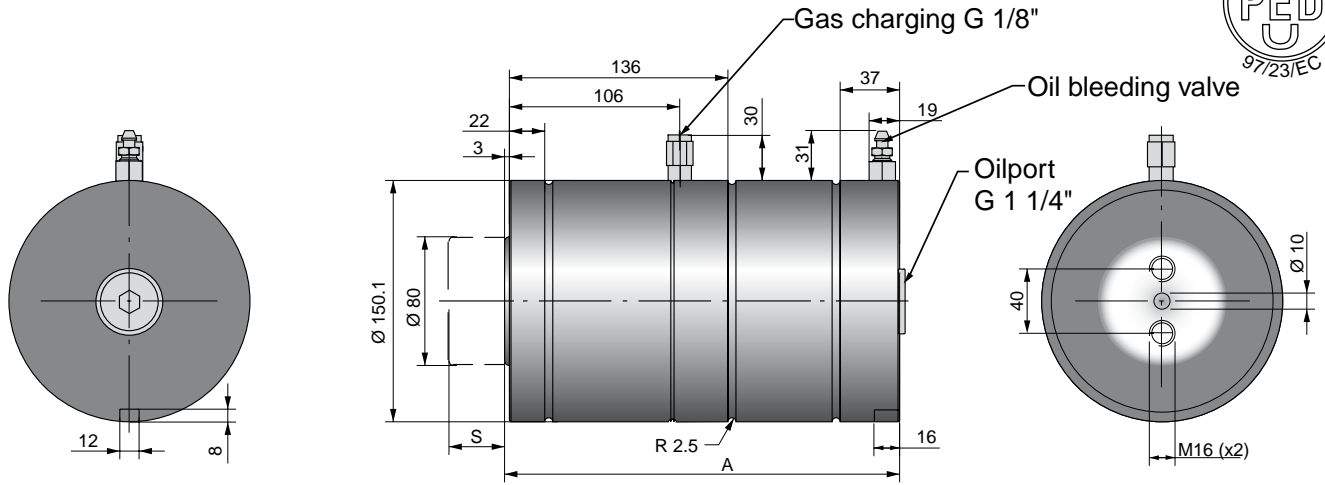

Volvo Part No.	Order No.	Working force* (kN)	Return force* (kN)	Stroke S (mm)	A	Weight (kg)
3055019	HCF 150-025	150	30	25	250	30.1
3055020	HCF 150-050	150	30	50	300	34.7
3055021	HCF 150-100	150	30	100	400	43.7
3055022	HCF 150-150	150	30	150	500	52.7

* = Nominal force for the operation

Flange mount for HCF 150 Order No. 2014677-7500

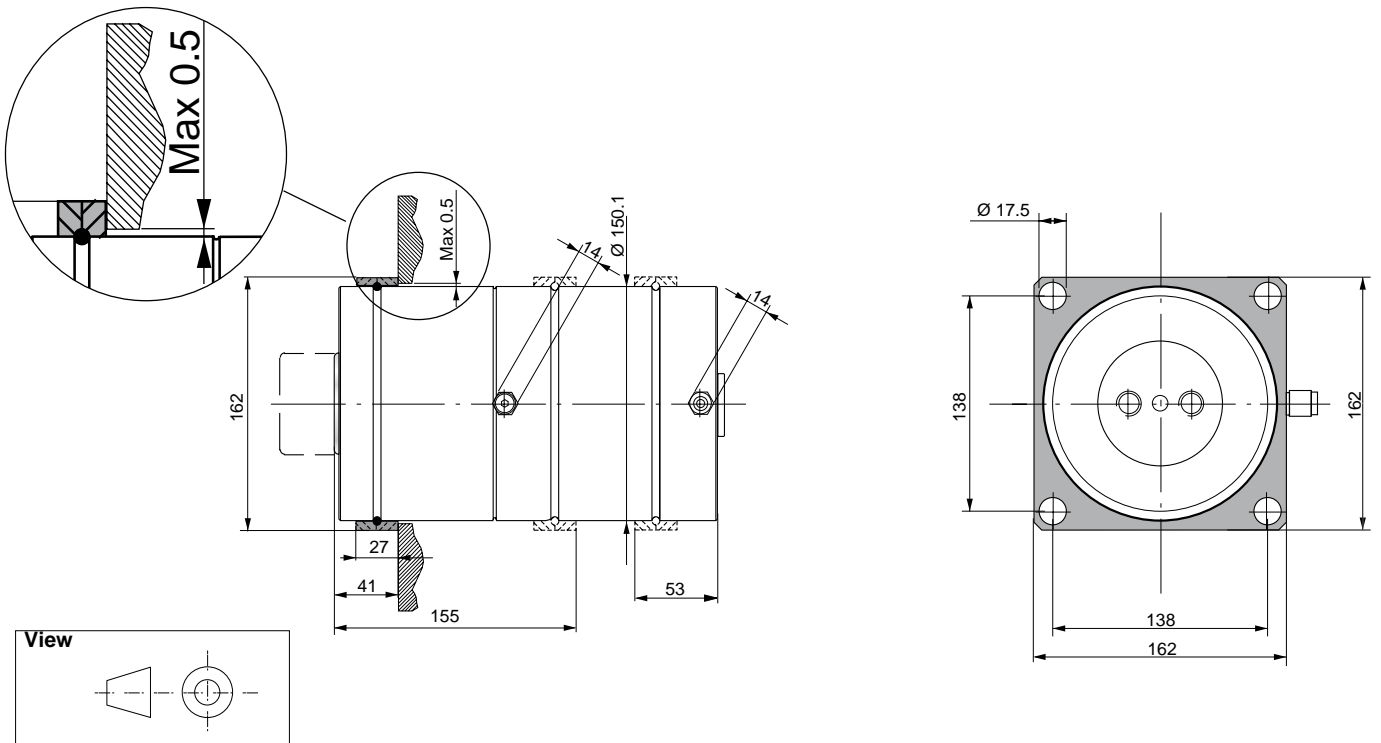

HCF-SP 150

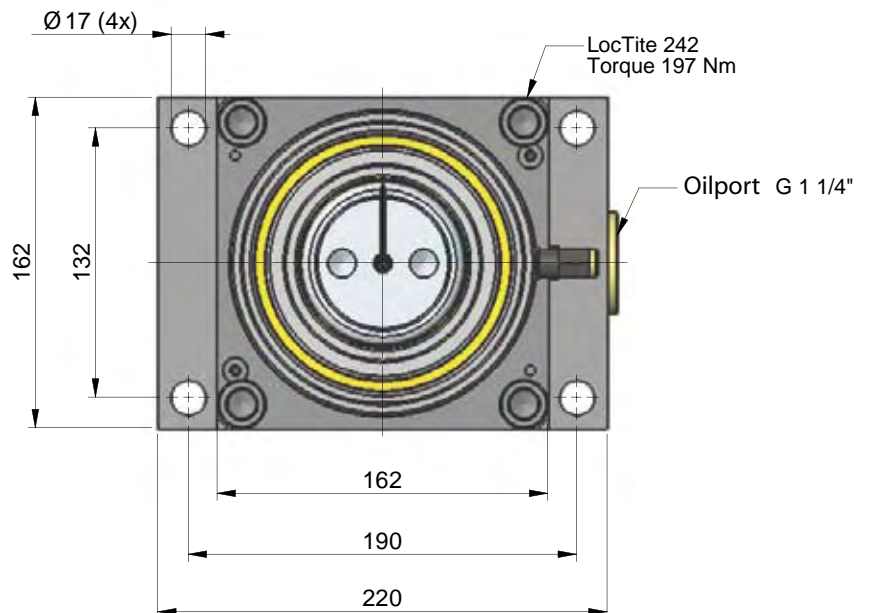
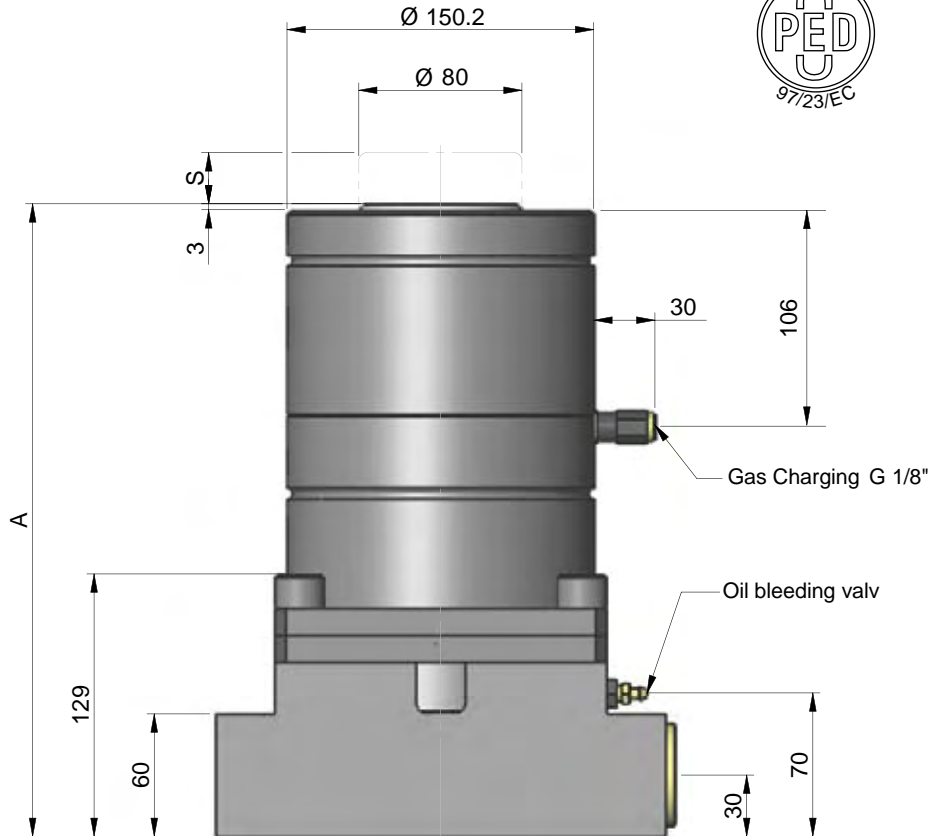
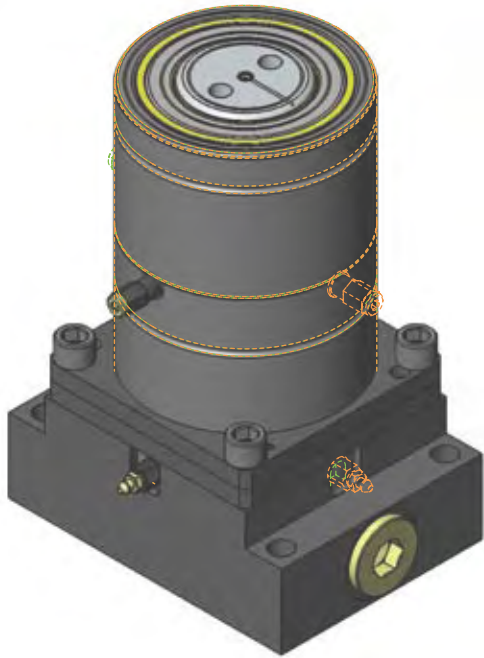

Volvo Part No.	Order No.	Working force* (kN)	Stroke S (mm)	A	Weight [kg]
3055023	HCF-SP 150-025	150	25	310	48.6
3055024	HCF-SP 150-050	150	50	360	53.2
3055025	HCF-SP 150-100	150	100	460	62.2

*= Nominal force for the operation

Dimensions for accessories

Sensor kit, option for Compact Cam, CC and CC-H

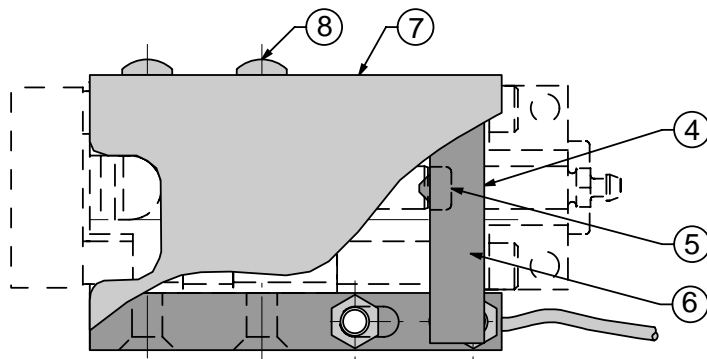
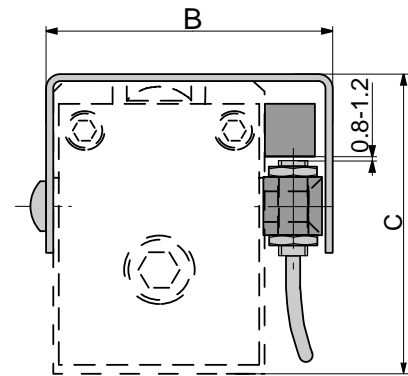
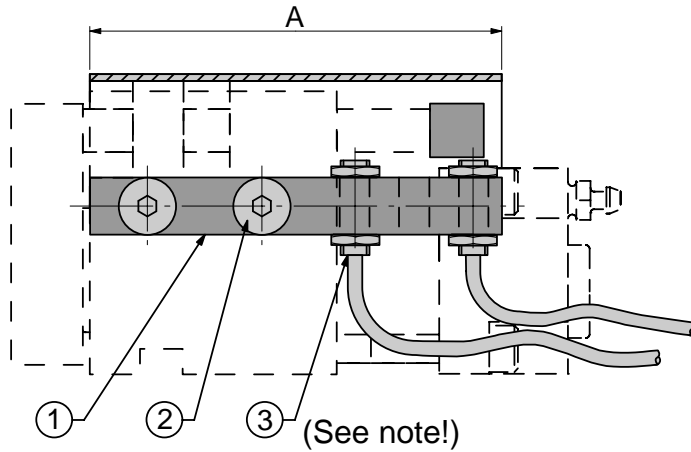

2 pcs Sensors
Order No. 503550 (sold separately)

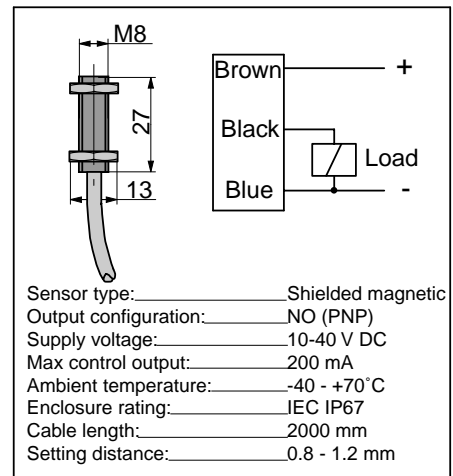

Note!

The 2 pcs Sensors (Order No. 503550) are sold separately and are not included in the Sensor kits themselves.

Sensor kit contents list

Position	Quantity	Description
1	1	Fixture
2	2	Screws
3	2	Sensors
4	1	Triggering block
5	1 or 2	Centre location pin (except CC 060, 090, 150)
6	2	Screws
7	1	Cover plate
8	2	Screws

Volvo Part No.	Sensor kit Order No.*	Compact Cam	A	B	C
	30 182 08 -01	CC 015-024	115	81	84
	30 182 08 -02	CC 015-049	165	81	84
	30 182 08 -03	CC 040-024	168	117	107
	30 182 08 -04	CC 040-049	193	117	107
	30 182 08 -05	CC 040-099	271	117	107
	30 182 08 -15	CC 040-124	321	117	107
	30 182 08 -09	CC 060-024	171	142	135
	30 182 08 -10	CC 060-049	196	142	135
	30 182 08 -11	CC 060-099	271	142	135
	30 182 08 -06	CC 090-024	216	170	172
	30 182 08 -07	CC 090-049	241	170	172
	30 182 08 -08	CC 090-099	316	170	172
	30 182 08 -12	CC 150-024	216	182	207
	30 182 08 -13	CC 150-049	241	182	207
	30 182 08 -14	CC 150-099	316	182	207

Security Block according to CNOMO-Standard (Renault and Peugeot/Citroen)

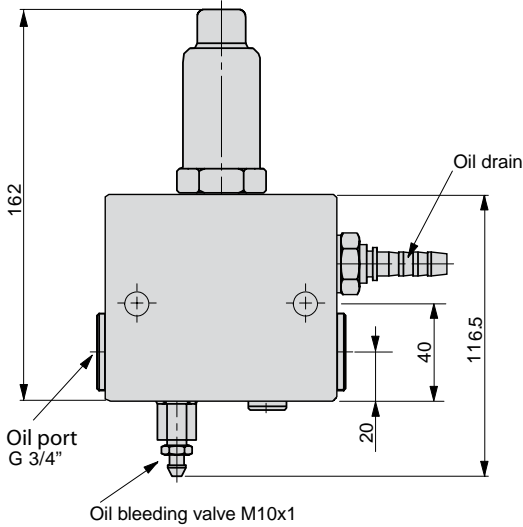
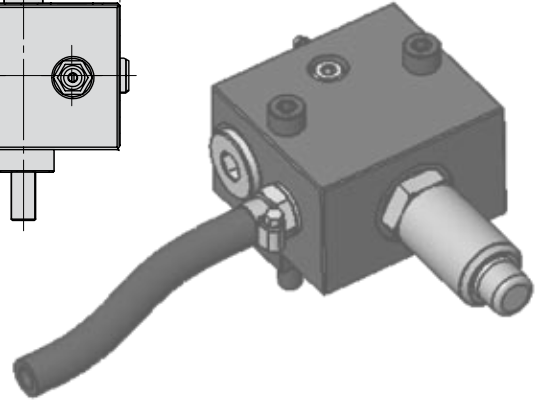
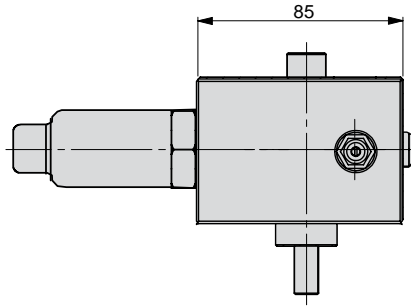
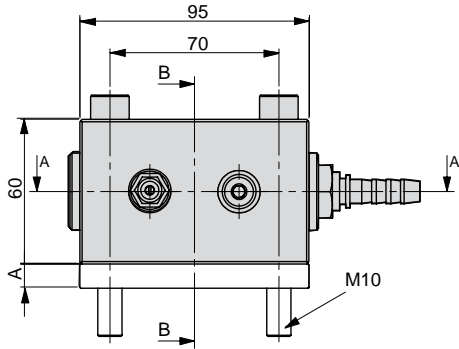

Volvo Part No.	Order No.	Size	A*
	3020008-015	015	10
	3020008-040	040	22.5
	3020008-060	060	32.5
	3020008-090	090	44
	3020008-150	150	70

*To be used when directly connected to the accumulator, see below.

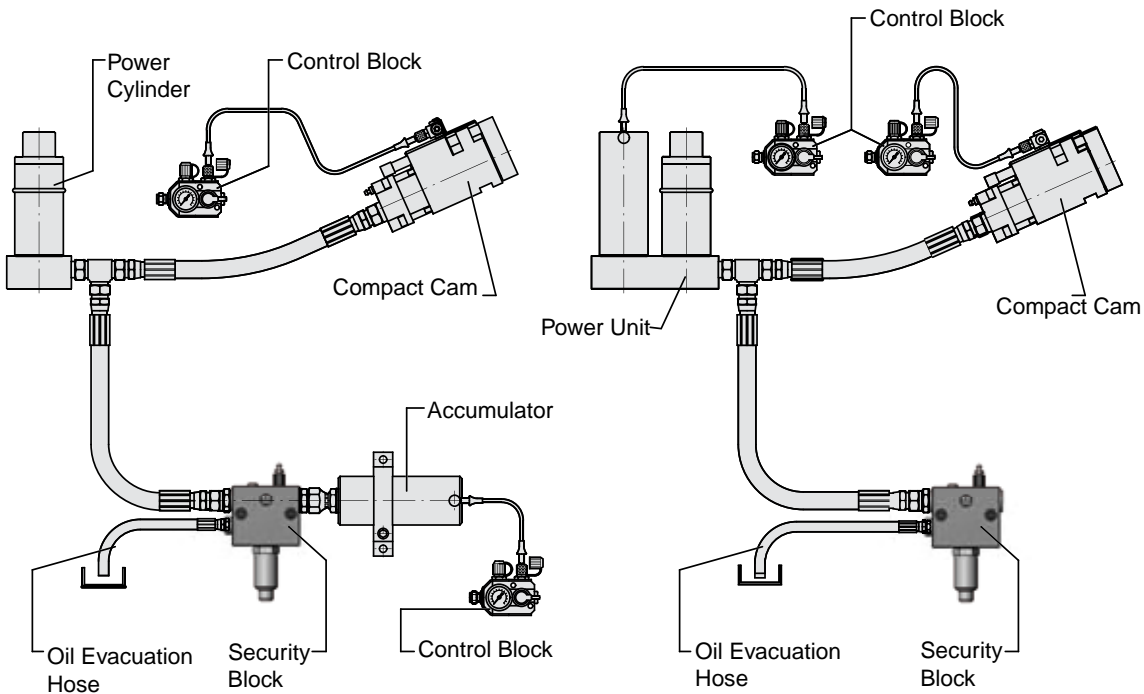

System hoses

EO24-Hose Dimensions

ISO standard: DIN EN ISO 8434

Hose, straight – straight

(45-90° hose ends not available, see 45-90° adapters)

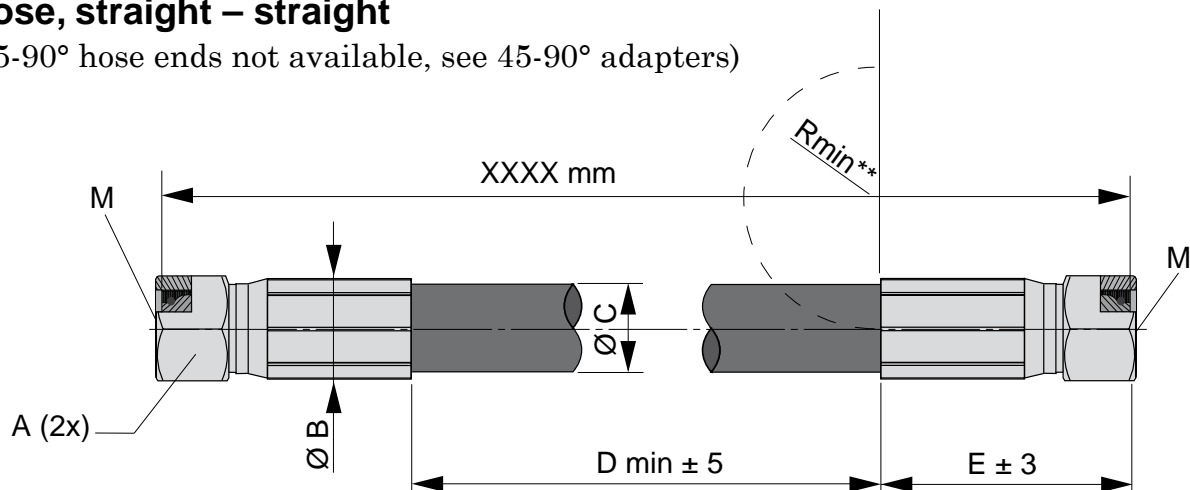

Volvo Part No.	For Power Unit	Hose size	Thread M	Order No.	A	Ø B	Ø C	D min	E	Rmin*
3054998	HCP 015 *	3/8" *	M 20x1.5	30 222 15 - xxxx	24	24.5	20	50	56	63
3055026	HCP 015	1/2"	M 24x1.5	30 214 54 - xxxx	30	28.5	24	50	63	90
3055027	HCP 040	3/4"	M30x2	30 214 55 - xxxx	36	35	31	50	72	120
3055028	HCP 060 and 090	1"	M36x2	30 214 56 - xxxx	46	44	38	50	88	150
3057029	HCP 150	1 1/4"	M42x2	30 214 57 - xxxx	50	55	50	50	114	250

** = Smallest recommended bending radius for the hydraulic hose

* = Hose size depends on press velocity, see below:

Power Unit	Standard hose size Max velocity 0.8 m/s	0.6 m/s	0.4 m/s	0.2 m/s
HCP 015	1/2"	3/8"	3/8"	3/8"
HCP 040	3/4"	3/4"	1/2"	1/2"
HCP 060	1"	3/4"	3/4"	1/2"
HCP 090	1"	1"	3/4"	1/2"
HCP 150	1 1/4"	1 1/4"	1"	3/4"

Additional Parker hose info:

Hose size	Inner Ø	Outer Ø	Hose	Max working pressure	Min burst pressure	Hose fitting
3/8"	10	20	721TC-6	280 bar	1120 bar	1C971-12-6
1/2"	12.5	24	721TC-8	280 bar	1120 bar	1C971-16-8
3/4"	19	31	721TC-12	280 bar	1120 bar	1C971-20-12
1"	25	38	721TC-16	280 bar	1120 bar	1C971-25-16
1 1/4"	31.8	47	721TC-20	210 bar	840 bar	1C971-30-20

Note: When ordering hoses direct from Parker make sure to include inside washing and end plugs. This procedure is included when ordering hoses from KALLER.

Hose Clamp

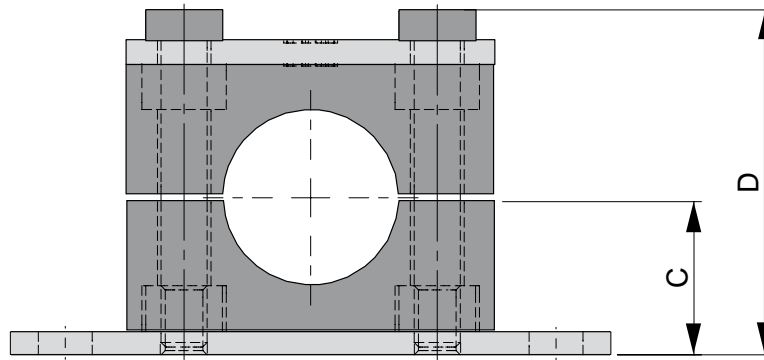

8

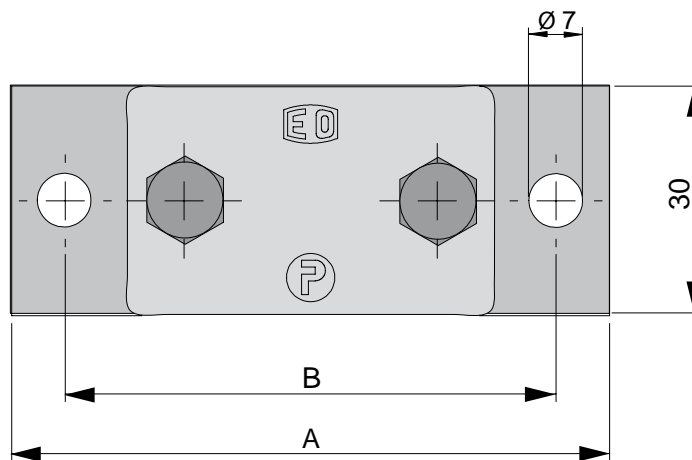

Volvo Part No.	Hose size	Order No.	A	B	C	D
3055030	3/8"	504613	78	64	20	44
3055031	1/2"	504614	78	64	20	44
3055032	3/4"	504615	87	73	24	51
3055033	1"	504616	100	86	32	67
3055034	1 1/4"	504617	116	100	36	75

Male Stud Connector

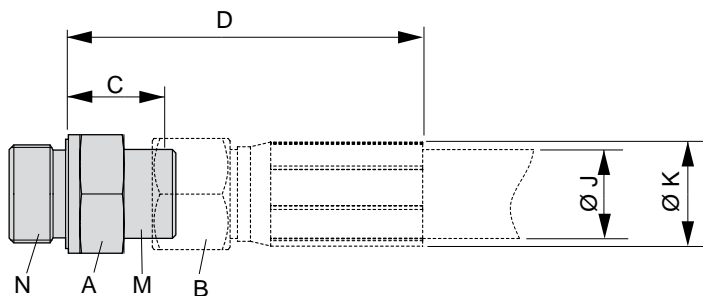

Hose size	Thread M	Thread N	Order No.	A	B	C	D	ØJ	ØK
3/8"	M 20x1.5	G 1/2"	504598	27	24	18	74	20	24.5
1/2"	M 24x1.5	G 1/2"	504321	27	30	19	82	24	30
1/2"	M24x1.5	G 3/4"	504322	32	30	21	84	24	30
3/4"	M30x2	G 1/2"	504323	32	36	21	93	31	37
3/4"	M30x2	G 3/4"	504324	32	36	21	93	31	37
3/4"	M30x2	G 1 1/4"	504325	50	36	23	95	31	37
1"	M36x2	G 1/2"	504326	41	46	23	111	38	46
1"	M36x2	G 3/4"	504327	41	46	23	111	38	46
1"	M36x2	G 1 1/4"	504328	50	46	23	111	38	46
1 1/4"	M42X2	G 3/4"	504329	41	50	24	138	46	57
1 1/4"	M42X2	G 1"	504330	46	50	24	138	46	57
1 1/4"	M42X2	G 1 1/4"	504331	50	50	27	141	46	57

Swivel Connector

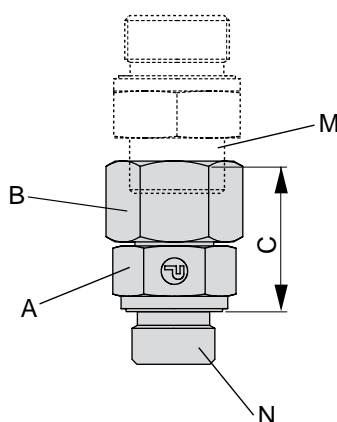

Thread M	Thread N	Order No.	A	B	C
M 20x1.5	G 1/2"	504608	27	24	35
M 24x1.5	G 1/2"	504609	27	30	37
M 30x2	G 3/4"	504610	32	36	43
M 36x2	G 1"	504611	41	46	48
M 42x2	G 1 1/4"	504612	50	50	51

Swivel Nut Elbow and Male Stud Connector

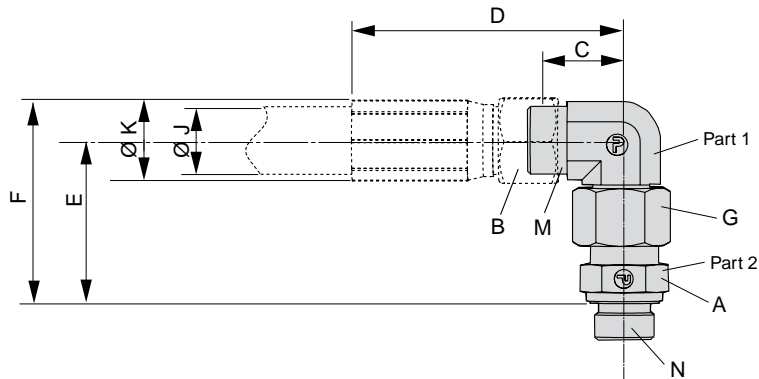

Hose size	Thread M	Thread N	Order No. Part 1	Order No. Part 2	A	B	C	D	E	F	G	ØJ	ØK
3/8"	M20x1.5	G 1/2"	504599	504598	27	24	22	78	49	61	24	20	24,5
1/2"	M24x1.5	G 1/2"	504332	504321	27	30	25	88	55	70	30	24	30
1/2"	M24x1.5	G 3/4"	504332	504322	32	30	25	88	58	73	30	24	30
3/4"	M30x2	G 1/2"	504333	504323	32	36	27	99	65	84	36	31	37
3/4"	M30x2	G 3/4"	504333	504324	32	36	27	99	65	84	36	31	37
3/4"	M30x2	G 1 1/4"	504333	504325	50	36	27	99	67	86	36	31	37
1"	M36x2	G 1/2"	504334	504326	41	46	30	118	73	96	46	38	46
1"	M36x2	G 3/4"	504334	504327	41	46	30	118	73	96	46	38	46
1"	M36x2	G 1 1/4"	504334	504328	50	46	30	118	73	96	46	38	46
1 1/4"	M42x2	G 3/4"	504335	504329	41	50	36	150	79	108	50	46	57
1 1/4"	M42x2	G 1 1/4"	504335	504331	50	50	36	150	79	108	50	46	57

Adjustable Locknut Elbow

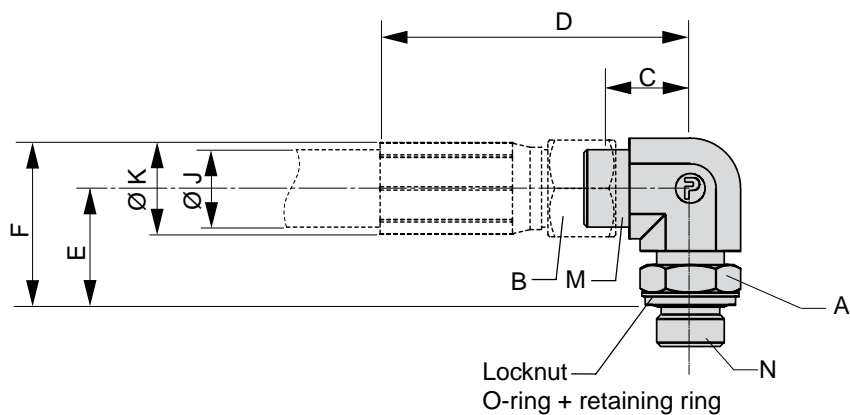

Hose size	Thread M	Thread N	Order No.	A	B	C	D	E	F	ØJ	ØK
3/8"	M20x1.5	G 1/2"	504600	27	24	22	78	36	48	20	24,5
1/2"	M24x1.5	G 1/2"	504336	27	30	25	88	36	51	24	30
3/4"	M30x2	G 3/4"	504337	36	36	28	100	39	58	31	37
1"	M36x2	G 3/4"	504338	41	46	30	118	44	67	38	46
1 1/4"	M42x2	G 1 1/4"	--	--	--	--	--	--	--	--	--

Swivel Nut 45° Elbow and Male Stud Connector

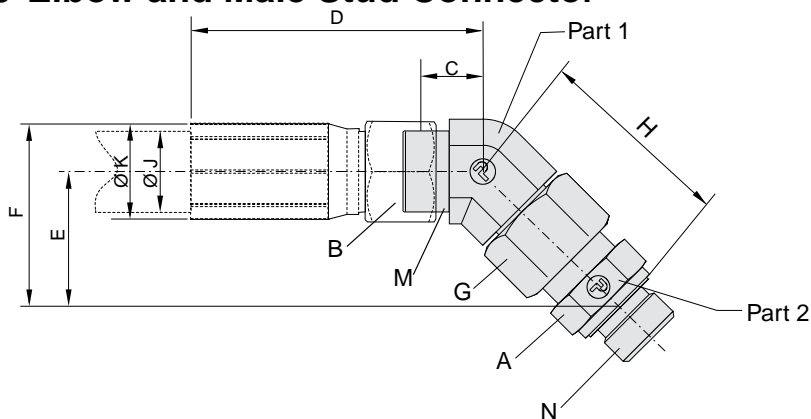

Hose size	Thread M	Thread N	Order No. Part 1	Order No. Part 2	A	B	C	D	E	F	G	H	ØJ	ØK
3/8"	M20x1.5	G 1/2"	504601	504598	27	24	17	73	35	47	24	49	20	24.5
1/2"	M24x1.5	G 1/2"	504339	504321	27	30	16	79	39	54	30	55	24	30
1/2"	M24x1.5	G 3/4"	504339	504322	32	30	16	79	40	55	30	57	24	30
3/4"	M30x2	G 1/2"	504340	504323	32	36	16	88	46	65	36	65	31	37
3/4"	M30x2	G 3/4"	504340	504324	32	36	16	88	46	65	36	65	31	37
3/4"	M30x2	G 1 1/4"	504340	504325	50	36	16	88	47	66	36	67	31	37
1"	M36x2	G 1/2"	504341	504326	41	46	19	107	52	75	46	73	38	46
1"	M36x2	G 3/4"	504341	504327	41	46	19	107	52	75	46	73	38	46
1"	M36x2	G 1 1/4"	504341	504328	50	46	19	107	52	75	46	73	38	46
1 1/4"	M42x2	G 3/4"	504342	504329	41	50	24	138	56	85	50	79	46	57
1 1/4"	M42x2	G 1 1/4"	504342	504331	50	50	24	138	56	85	50	79	46	57

Swivel Nut Branch Tee and Male Stud Connector

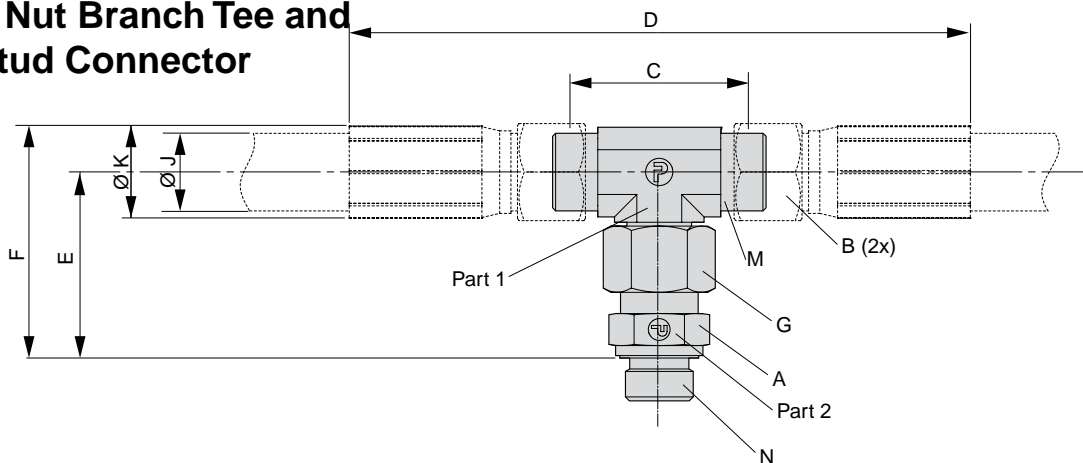

Hose size	Thread M	Thread N	Order No. Part 1	Order No. Part 2	A	B	C	D	E	F	G	ØJ	ØK
3/8"	M20x1.5	G 1/2"	504602	504598	27	24	43	155	49	61	24	20	24.5
1/2"	M24x1.5	G 1/2"	504343	504321	27	30	49	175	55	70	30	24	30
1/2"	M24x1.5	G 3/4"	504343	504322	32	30	49	175	58	73	30	24	30
3/4"	M30x2	G 1/2"	504344	504323	32	36	53	197	65	84	36	31	37
3/4"	M30x2	G 3/4"	504344	504324	32	36	53	197	65	84	36	31	37
3/4"	M30x2	G 1 1/4"	504344	504325	50	36	53	197	67	86	36	31	37
1"	M36x2	G 1/2"	504345	504326	41	46	60	236	73	96	46	38	46
1"	M36x2	G 3/4"	504345	504327	41	46	60	236	73	96	46	38	46
1"	M36x2	G 1 1/4"	504345	504328	50	46	60	236	73	96	46	38	46
1 1/4"	M42x2	G 3/4"	504346	504329	41	50	71	299	79	108	50	46	57
1 1/4"	M42x2	G 1 1/4"	504346	504331	50	50	71	299	79	108	50	46	57

Swivel Nut Run Tee and Male Stud Connector

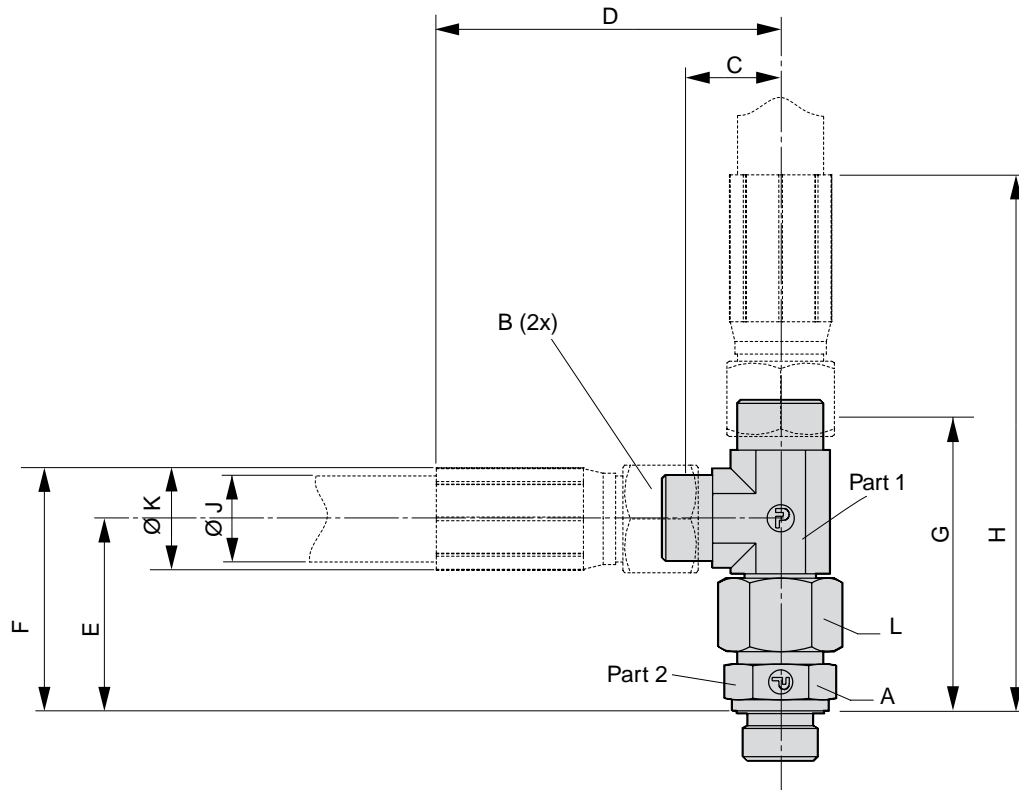

Hose size	Thread M	Thread N	Order No. Part 1	Order No. Part 2	A	B	C	D	E	F	G	H	Ø J	Ø K
3/8"	M20x1.5	G 1/2"	504603	504598	27	24	22	78	49	61	71	127		
1/2"	M24x1.5	G 1/2"	504347	504321	27	30	25	88	55	70	80	143	24	30
1/2"	M24x1.5	G 3/4"	504347	504322	32	30	25	88	58	73	82	145	24	30
3/4"	M30x2	G 1/2"	504348	504323	32	36	27	99	65	84	92	164	31	37
3/4"	M30x2	G 3/4"	504348	504324	32	36	27	99	65	84	92	164	31	37
3/4"	M30x2	G 1 1/4"	504348	504325	50	36	27	99	67	86	94	166	31	37
1"	M36x2	G 1/2"	504349	504326	41	46	30	118	73	96	103	191	38	46
1"	M36x2	G 3/4"	504349	504327	41	46	30	118	73	96	103	191	38	46
1"	M36x2	G 1 1/4"	504349	504328	50	46	30	118	73	96	103	191	38	46
1 1/4"	M42X2	G 3/4"	504350	504329	41	50	36	150	79	108	114	228	46	57
1 1/4"	M42X2	G 1 1/4"	504350	504331	50	50	36	150	79	108	114	228	46	57

Union Straight

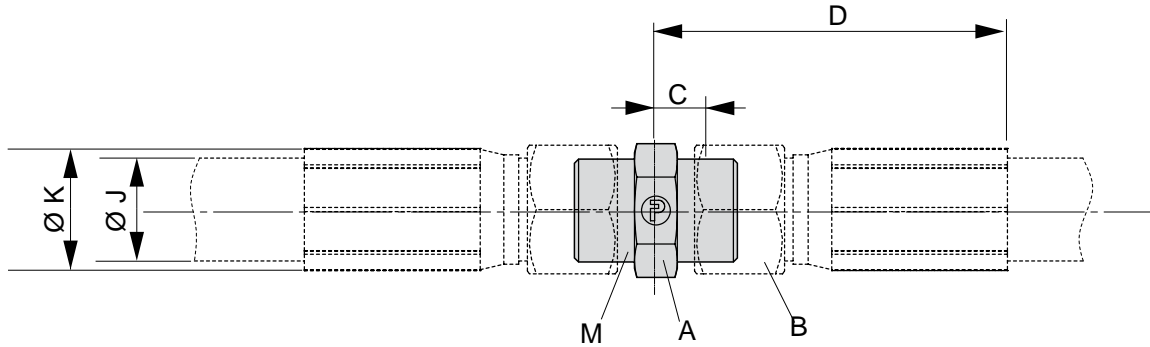

Hose size	Thread M	Order No.	A	B	C	D	Ø J	Ø K
3/8"	M20x1.5	504604	22	24	10	66	20	24.5
1/2"	M24x1.5	504351	27	30	11	74	24	30
3/4"	M30x2	504352	32	36	12	84	31	37
1"	M36x2	504353	41	46	13	101	38	46
1 1/4"	M42X2	504354	46	50	14	128	46	57

Union Elbow

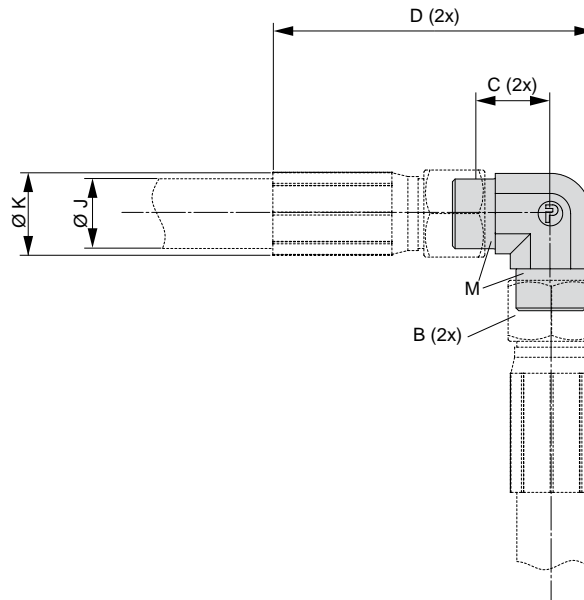

Hose size	Thread M	Order No.	B	C	D	Ø J	Ø K
3/8"	M20x1.5	504605	24	22	90	20	24.5
1/2"	M24x1.5	504355	30	25	102	24	30
3/4"	M30x2	504356	36	27	117	31	37
1"	M36x2	504357	46	30	140	38	46
1 1/4"	M42X2	504358	50	36	178	46	57

Union Tee

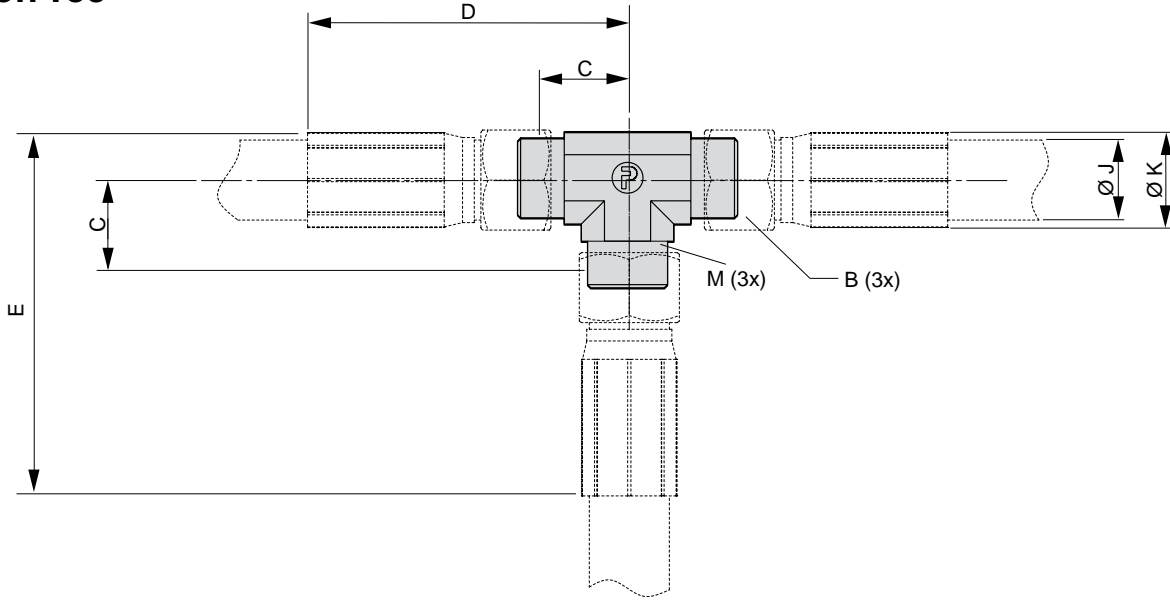

Hose size	Thread M	Order No.	B	C	D	E	Ø J	Ø K
3/8"	M20x1.5	504606	24	22	78	91	20	24.5
1/2"	M24x1.5	504359	30	25	88	103	24	30
3/4"	M30x2	504360	36	27	99	117	31	37
1"	M36x2	504361	46	30	118	140	38	46
1 1/4"	M42x2	504362	50	36	150	178	46	57

Union Cross

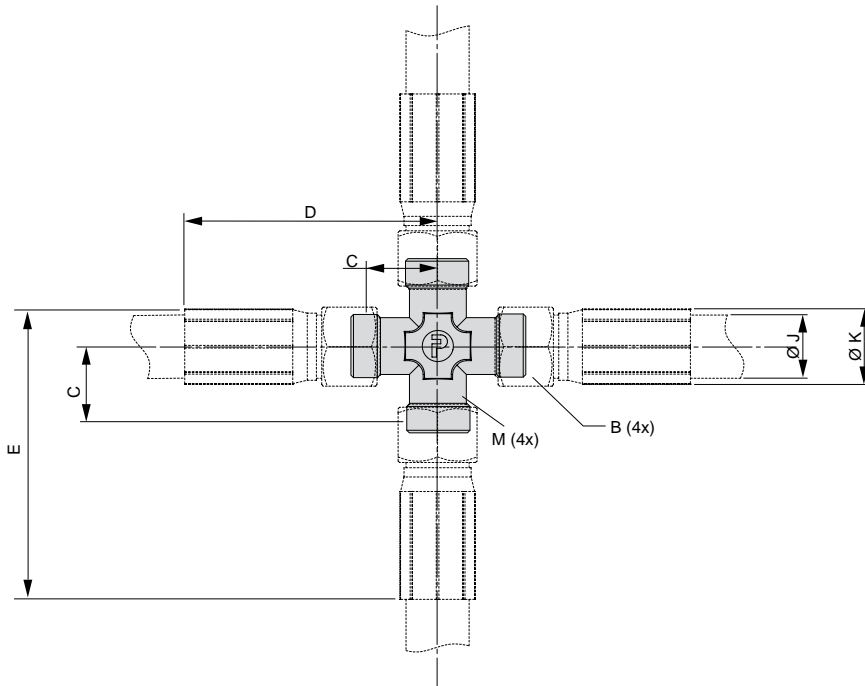

Hose size	Thread M	Order No.	B	C	D	E	Ø J	Ø K
3/8"	M20x1.5	504607	24	22	78	91	20	24.5
1/2"	M24x1.5	504363	30	25	88	103	24	30
3/4"	M30x2	504364	36	27	99	117	31	37
1"	M36x2	504365	46	30	118	140	38	46
1 1/4"	M42x2	504366	50	36	150	178	46	57

Additional Kaller - Parker adapter reference list:

KALLER Order No.	Parker Order No.
504321	GE16SREDOMD*
504322	GE16SR3/4EDOMD*
504323	GE20SR1/2EDOMD*
504324	GE20SREDOMD*
504325	GE20SR11/4EDOMD*
504326	GE25SR1/2EDOMD*
504327	GE25SR3/4EDOMD*
504328	GE25SR11/4EDOMD*
504329	GE30SR3/4EDOMD*
504330	GE30SR1EDOMD*
504331	GE30SREDOMD*
504332	EW16SOMD*
504333	EW20SOMD*
504334	EW25SOMD*
504335	EW30SOMD*
504336	WEE16SROMD*
504337	WEE20SROMD*
504338	WEE25SR3/4OMD*
504339	EV16SOMD*
504340	EV20SOMD*
504341	EV25SOMD*
504342	EV30SOMD*
504343	ET16SOMD*
504344	ET20SOMD*
504345	ET25SOMD*
504346	ET30SOMD*
504347	EL16SOMD*
504348	EL20SOMD*
504349	EL25SOMD*
504350	EL30SOMD*
504351	G16S*X
504352	G20S*X
504353	G25S*X
504354	G30S*X
504355	W16S*X
504356	W20S*X
504357	W25S*X
504358	W30S*X
504359	T16S*X
504360	T20S*X
504361	T25S*X
504362	T30S*X
504363	K16S*X
504364	K20S*X
504365	K25S*X
504366	K30S*X

KALLER Order No.	Parker Order No.
504598	GE12SR1/2EDOMD*
504599	EW12SOMD*
504600	WEE12SR1/2OMD*
504601	EV12SOMD*
504602	ET12SOMD*
504603	EL12SOMD*
504604	G12S*X
504605	W12S*X
504606	T12S*X
504607	K12S*X
504608	EGE12SR1/2ED*
504609	EGE16SRED*
504610	EGE20SRED*
504611	EGE25SRED*
504612	EGE30SRED*
504613	RAVG6-319
504614	RAVG6-323
504615	RAVG6-430
504616	RAVG6-538
504617	RAVG6-648

* **CF** version is Chromium⁶ free. **A3C** material is steel, Zink-plated and yellow chromated.

The **CF** version is recommended when available.

Parker ordering example:
GE16SREDOMDCF or **GE16SREDOMDA3C**

Manifold Block 3022834

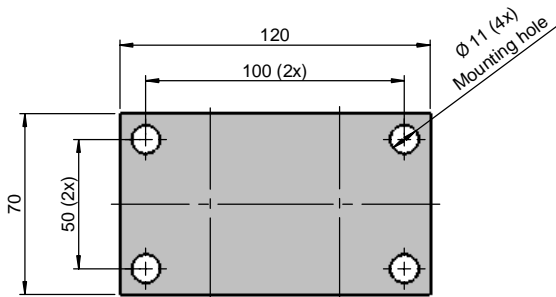
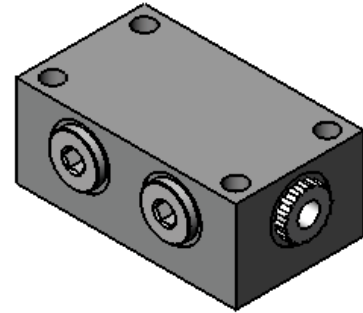
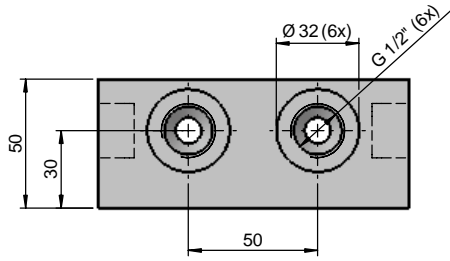

Manifold Block 3022835

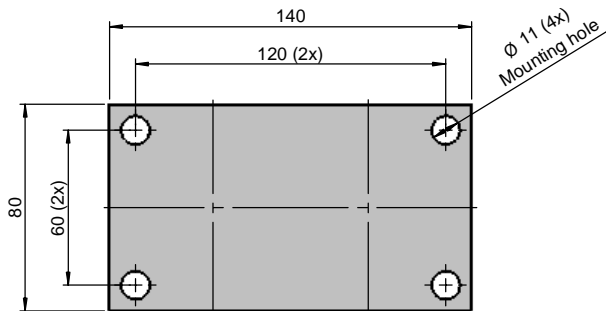
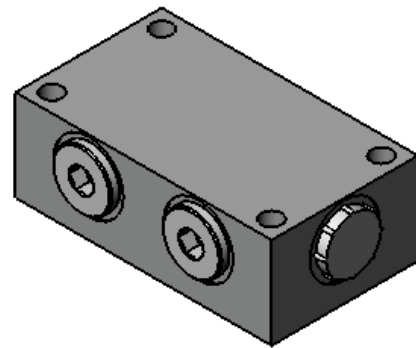
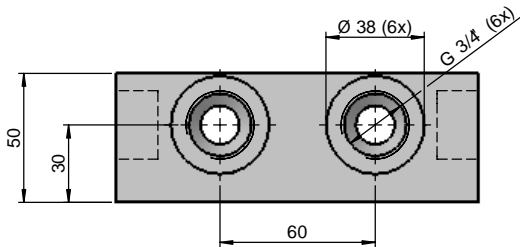

System adapters

Quick coupling

The quick coupling can be used to separate the Power Unit and the Cam Unit/ Force Cylinder without refilling and bleeding the system.

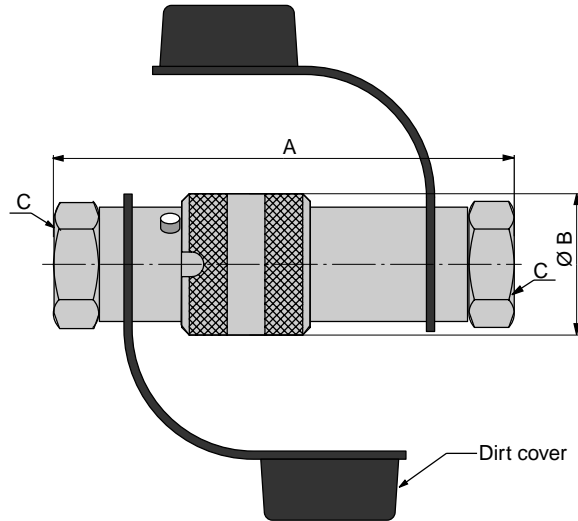

Ordering No.	A	ØB	C	Max oil flow	Power Unit / Cam	Max velocity Power Unit / Cam
3018084-01	132	40	G 1/2"	100 l/min	015	0.8
3018084-02	162	50	G 3/4"	300 l/min	040, 060, 090	0.8 (090=0.6)
3018084-03	176	57	G 1	500 l/min	150	0.6

Installation possibilities

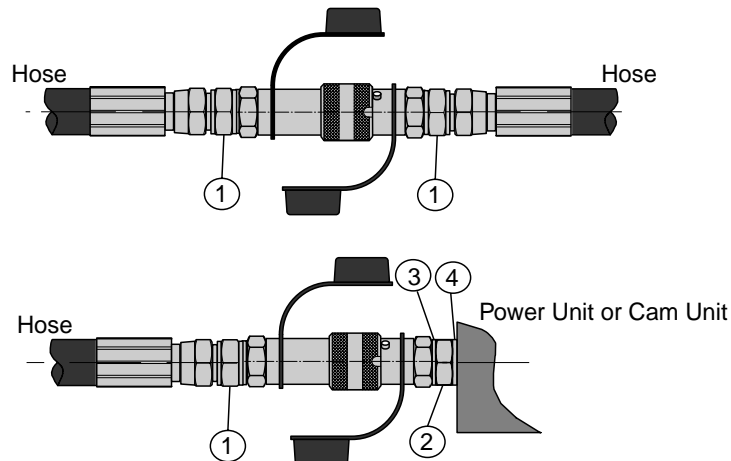

Ordering number adapter and washers				
Quick coupling	Position 1	Position 2	Position 3	Position 4
3018084-01	504321	503551	501271	501271
3018084-02	504324 or 504327*	503552	501270	501270
3018084-03	504330	503553	500282	503554

*for 1" hose size

Designing your hose system

How to design your hose system

1. Choose the right hose size and style from page 9.8/28 (the hose size is always dictated by the Power Unit size).
2. Choose the right size/style adaptor between hose and Power Unit using page 9.8/29-9.8/30. The oil connection is found on the respective Power Unit dimension page.
3. Choose the right size/style adapter between hose and Cam Unit/ Force Cylinder (CC or HCF) using page 9.8/29-9.8/30. The oil connection is found on the respective Cam Unit/ Force Cylinder dimension page. You can also connect one hose to another using adapters (see page 9.8/31-9.8/32).

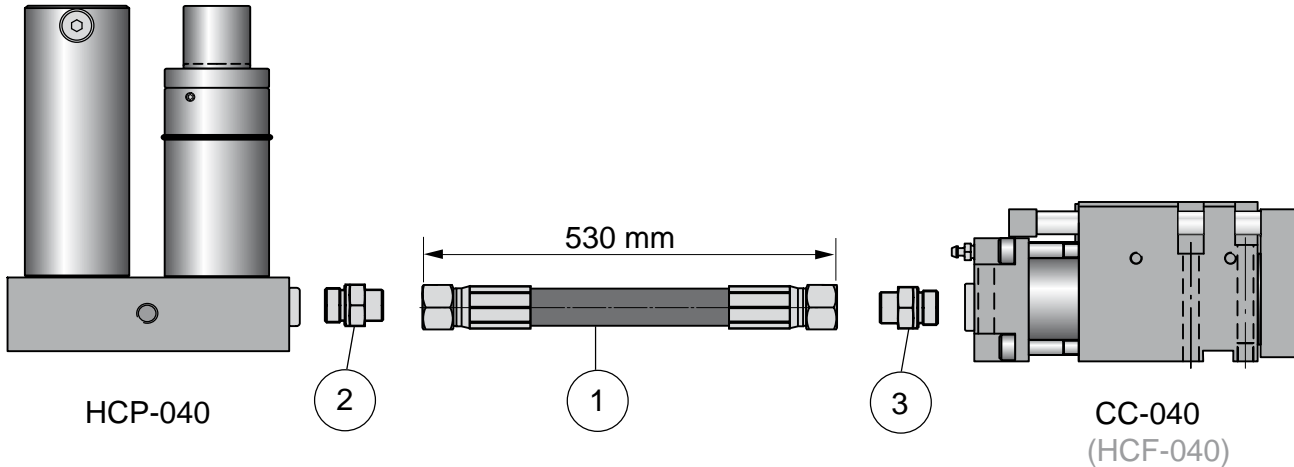

Example above showing how to connect a HCP-040 to a CC-040 (the same principal applies when connecting an HCF).

Position	Order No.
1	3021455-0530
2	504324
3	504324

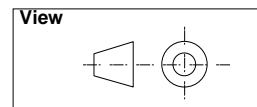

Designing your hose system

Example below showing how to connect a HCP-150 unit for two Cam Units CC-090 (the same principal applies when connecting an HCF).

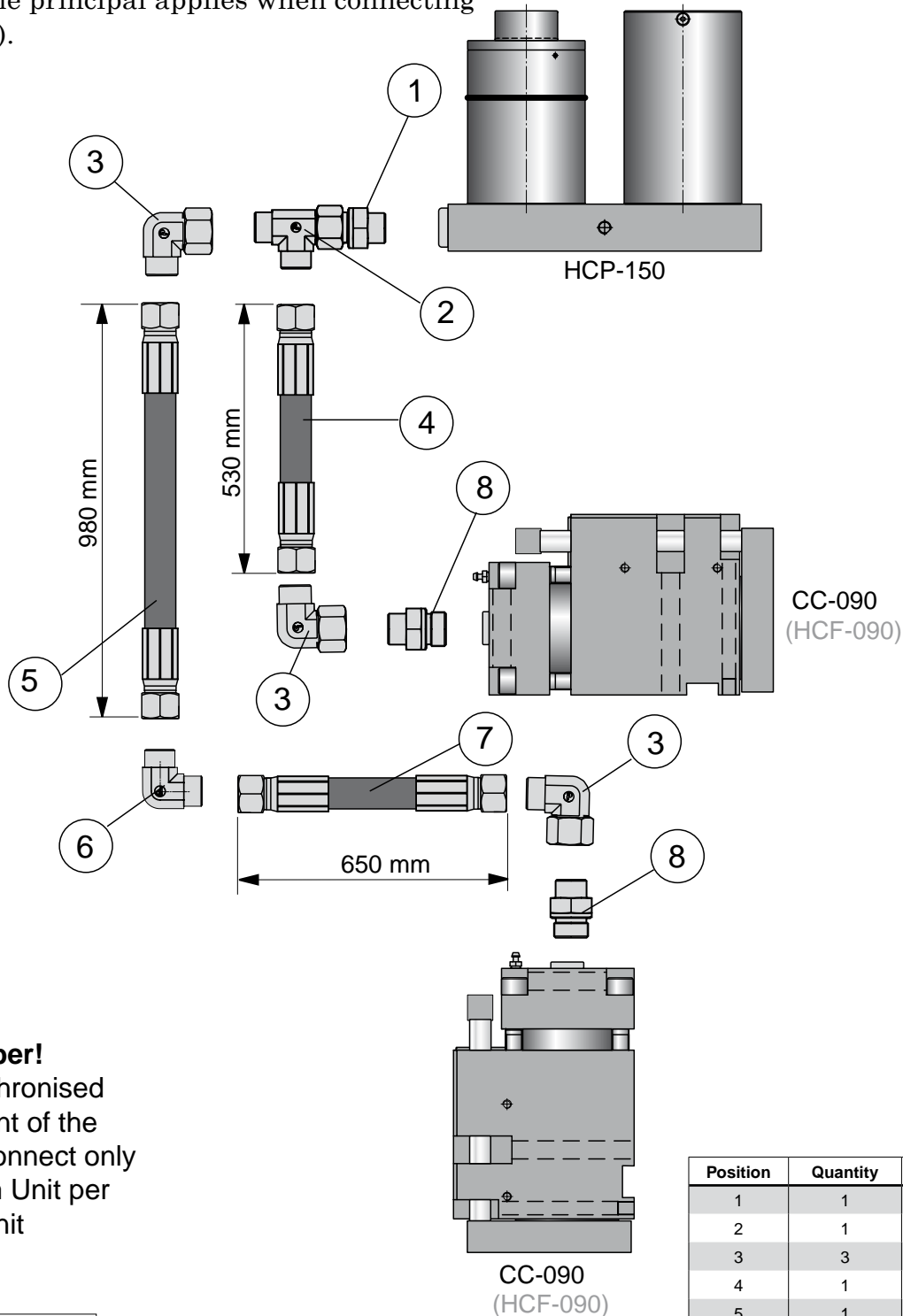

Remember!
For synchronised movement of the Cams, connect only one Cam Unit per Power Unit

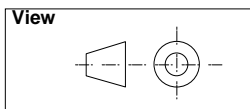

Position	Quantity	Order No.
1	1	504331
2	1	504350
3	3	504335
4	1	3021457-0530
5	1	3021457-0980
6	1	504358
7	1	3021457-0652
8	2	504329

Hose systems for Control Units and oil bleeding

CC-H Compact Cam/ HCP Power Unit (example)

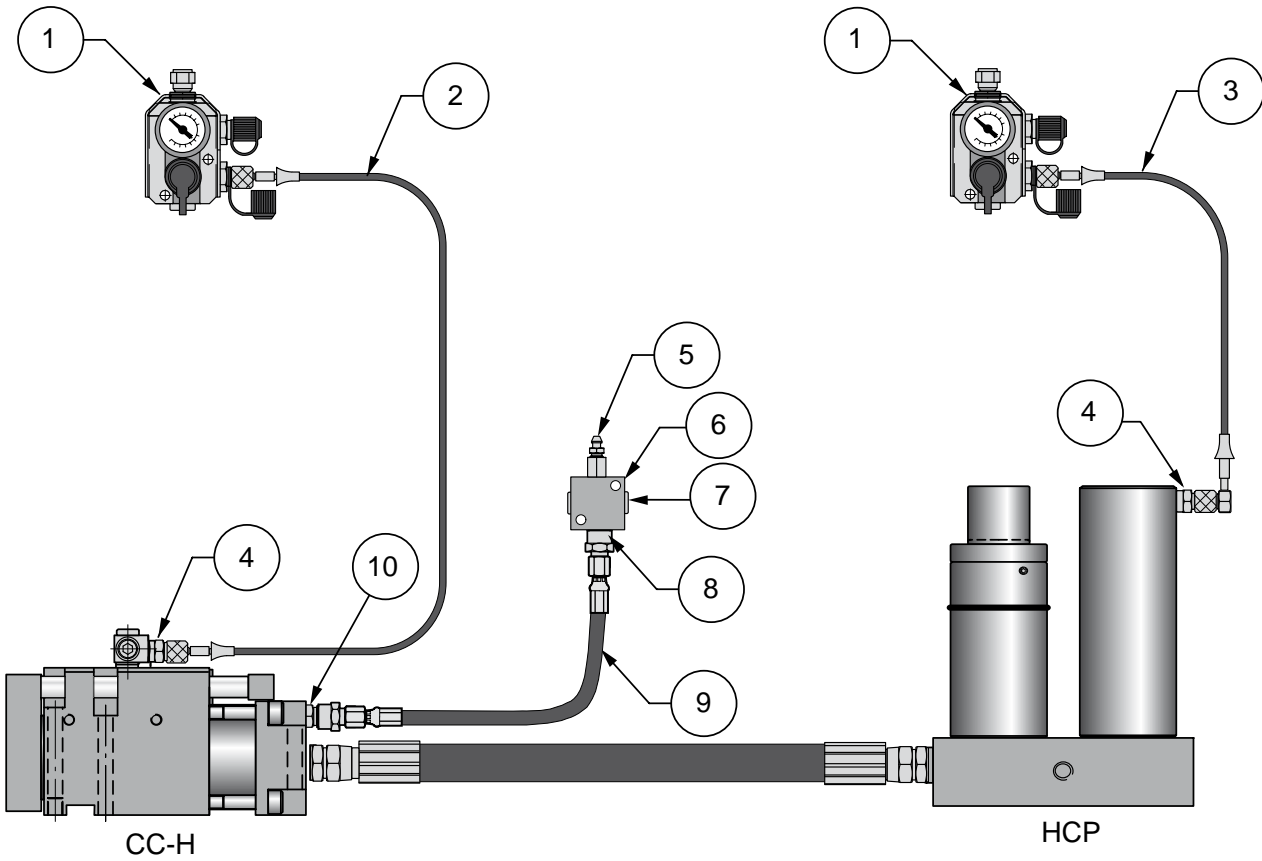

8

Hose system for Control Units			
Position	Quantity	Description	Order No.
1	2	Control Unit	3116114
2	1	EZ-hose	4014974-xxxx
3	1	EZ-hose	4017568-xxxx
4	2	Adapter	4114973-G 1/8"

Hose system for oil bleeding			
Position	Quantity	Description	Order No.
5	1	Bleed nipple	4014007
6	1	Coupling Unit	4017032
7	1	Plug G 1/8"	500343
8	1	Adapter	503593
9	1	EO24-hose	3020857-xxxx
10	1	Adapter M10x1	504636

Hose systems for Control Units and oil bleeding

Two CC-H Compact Cams / HCP Power Unit (example)

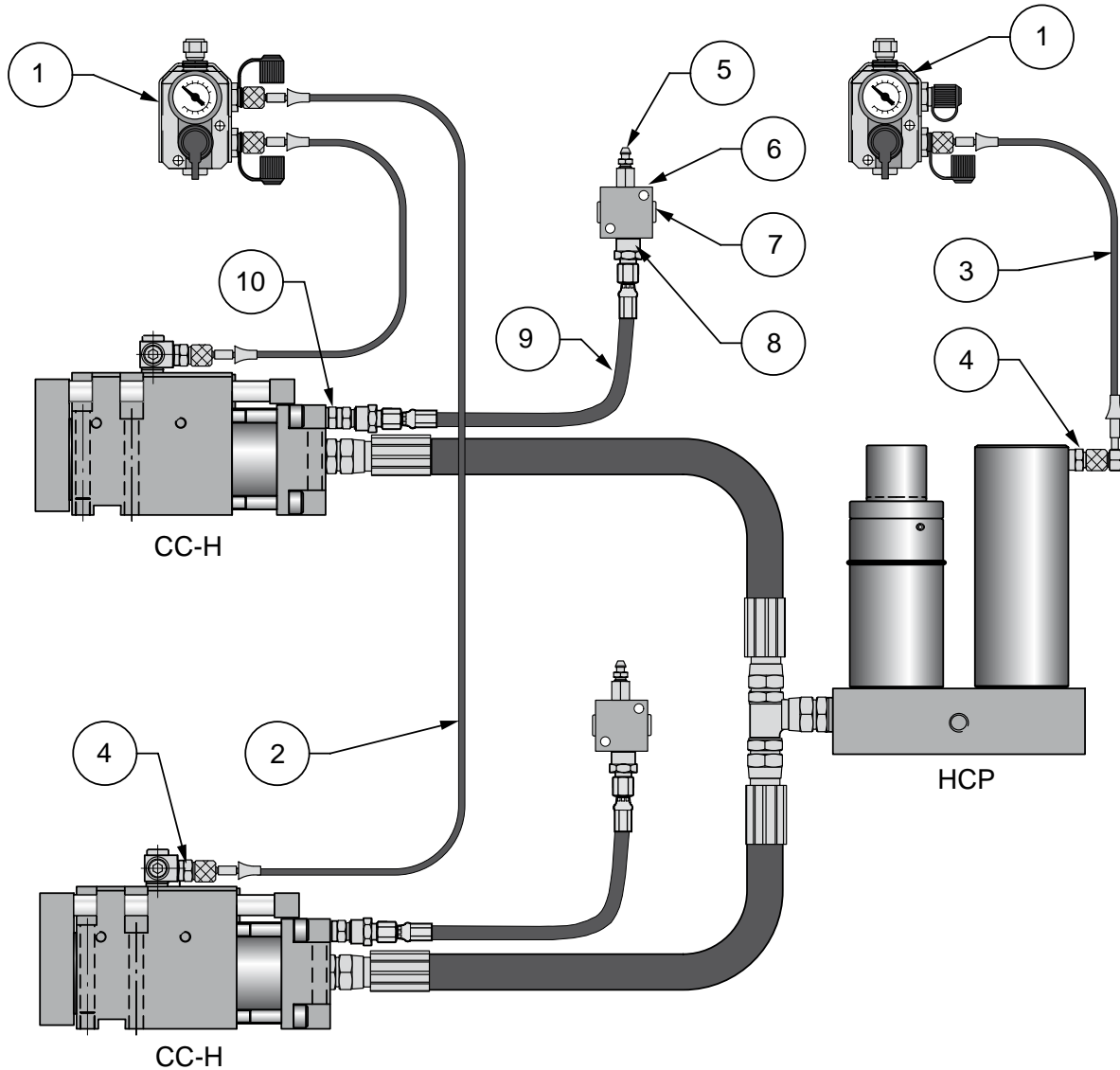

Hose system for Control Units			
Position	Quantity	Description	Order No.
1	2	Control Unit	3116114
2	2	EZ-hose	4014974-xxxx
3	1	Ez-hose	4017568-xxxx
4	3	Adapter	4114973-G 1/8"

Hose system for oil bleeding			
Position	Quantity	Description	Order No.
5	2	Bleed nipple	4014007
6	2	Coupling Unit	4017032
7	2	Plug G 1/8"	500343
8	2	Adapter	503593
9	2	EO24-hose	3020857-xxxx
10	2	Adapter M10x1	504636

Hose systems for Control Units and oil bleeding

Two HCF Force Cylinders / to two HCP Power Units (example)

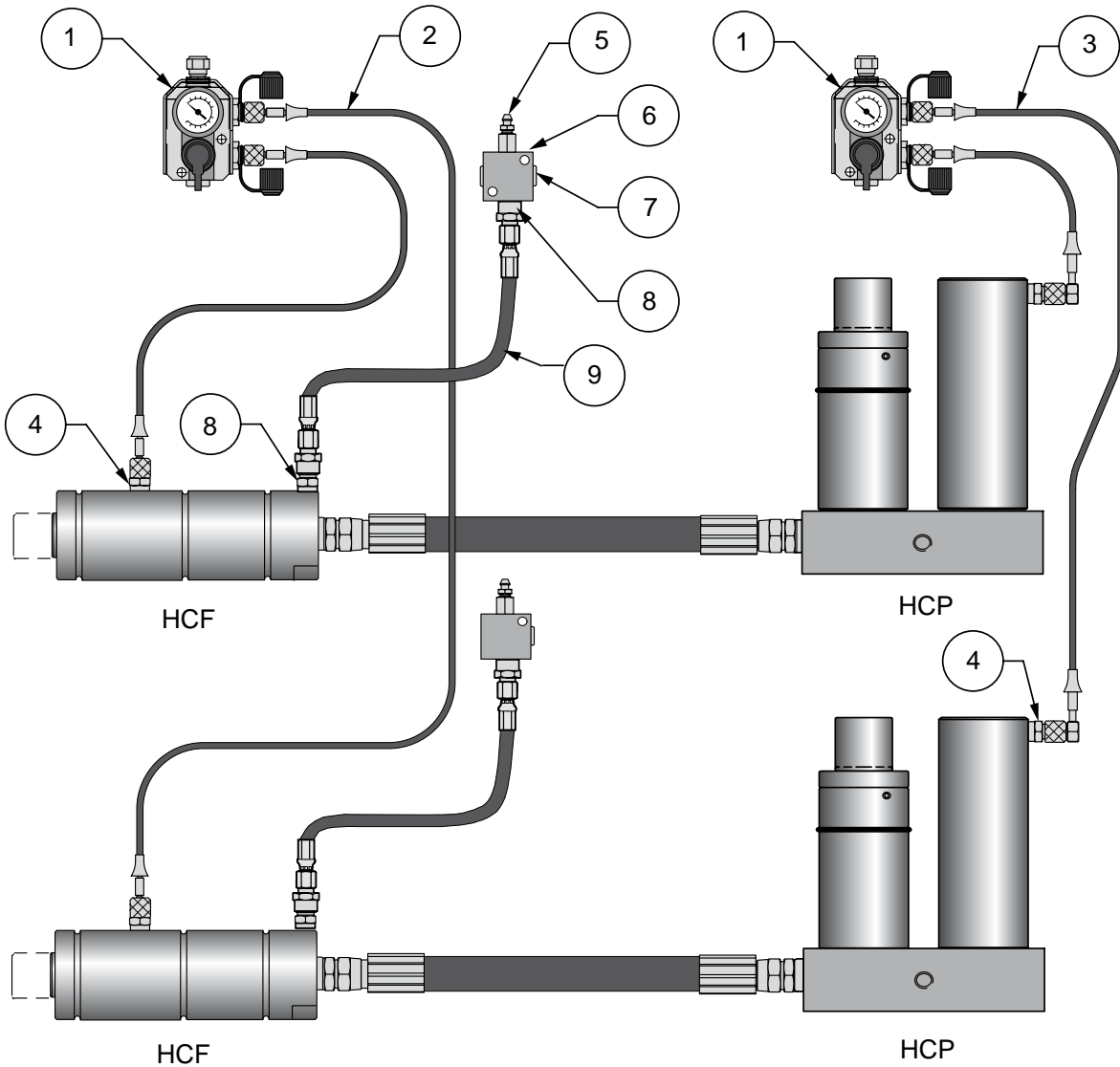

8

Hose system for Control Units			
Position	Quantity	Description	Order No.
1	2	Control Unit	3116114
2	2	EZ-hose	4014974-xxxx
3	2	EZ-hose	4017568-xxxx
4	4	Adapter	4114973-G 1/8"

Hose system for oil bleeding			
Position	Quantity	Description	Order No.
5	2	Bleed nipple	4014007
6	2	Coupling Unit	4017032
7	2	Plug G 1/8"	500343
8	4	Adapter	503593
9	2	EO24-hose	3020857-xxxx

Hose systems for Control Units and oil bleeding

Three HCF Force Cylinders to one HCP Power Unit (example)

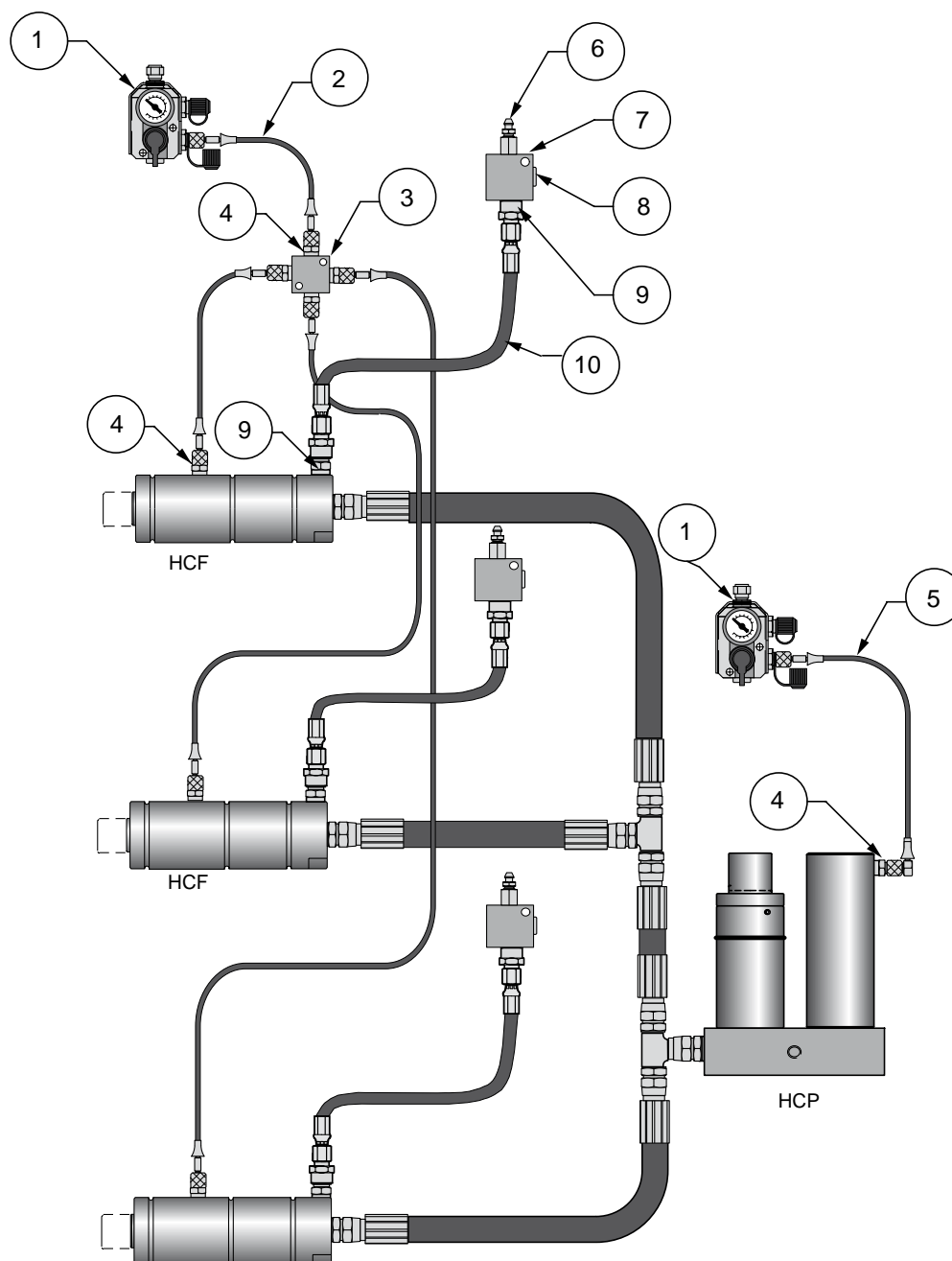

8

Hose system for Control Units

Position	Quantity	Description	Order No.
1	2	Controll Unit	3116114
2	4	EZ-hose	4014974-xxxx
3	1	Coupling Unit	4017032
4	8	Adapter	4114973-G 1/8"
5	1	EZ-hose	4017568-xxxx

Hose system for oil bleeding

Position	Quantity	Description	Order No.
6	3	Bleed nipple	4014007
7	3	Coupling Unit	4017032
8	3	Plug G 1/8"	500343
9	6	Adapter	503593
10	3	EO24-hose	3020857-xxxx

Pump Unit

Order No. 3017075

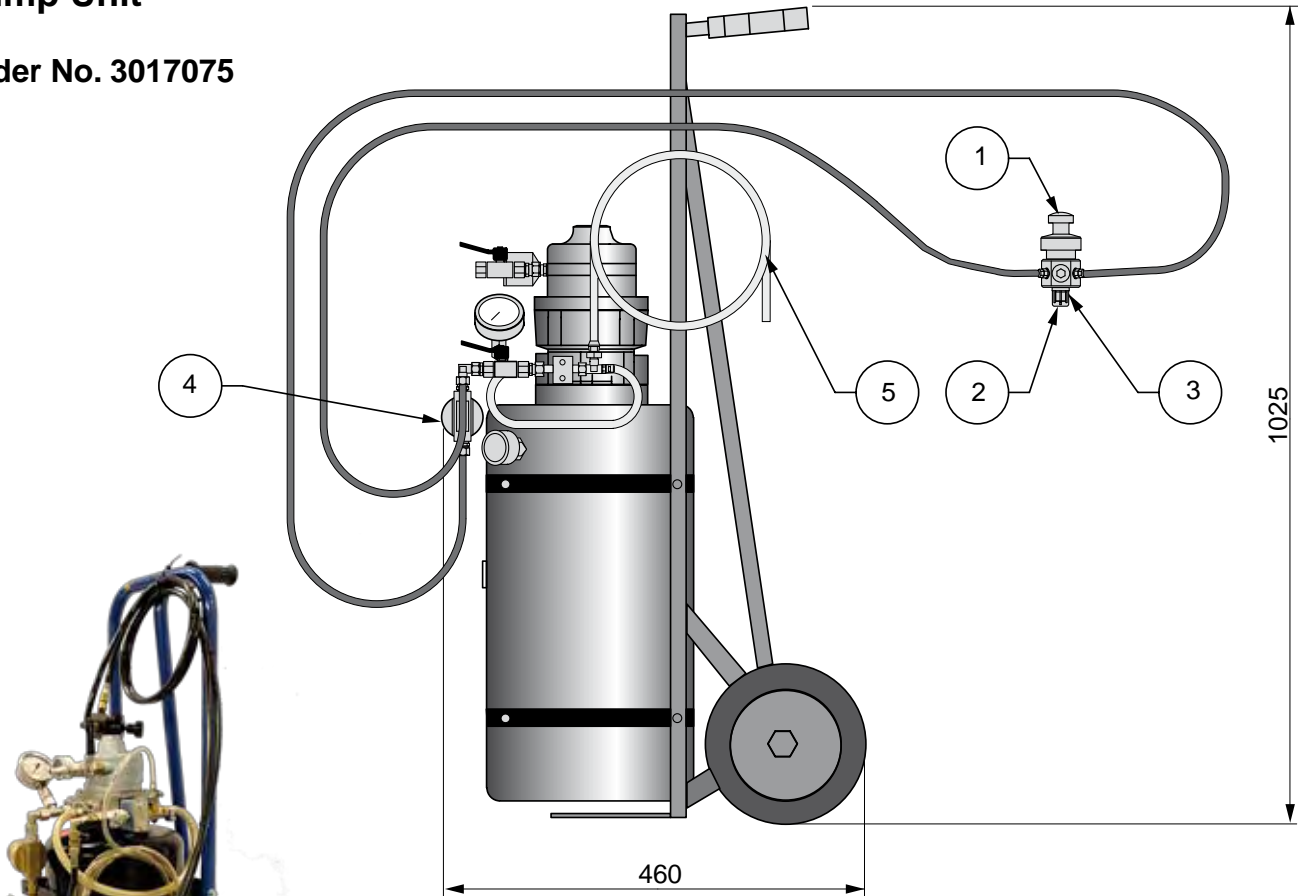

Technical specifications	
Oil flow:.....	2.4 l/min at 1500 rpm
Max oil pressure:.....	55 bar
Tank volume:.....	18 litres
Oil filter:.....	10 µm
Air pressure.....	5-7 bar

The hook spanner below is used to hold the piston in place when loosening/tightening the port plug.

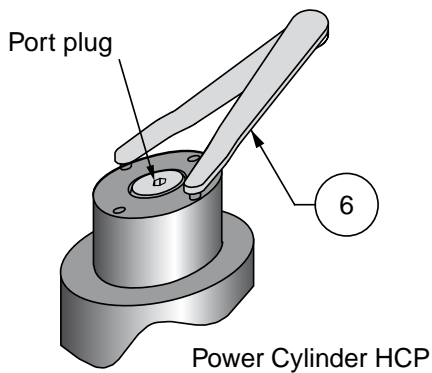

Spare parts etc.		
Position	Description	Order No.
1	Armature (include position 2 and 3)	3013941
2	Plastic plug	502446
3	Rubber-steel washer	502160
4	Filter	503419
5	Transparent hose	503116
6	Hook spanner (HCP 015)	503417
6	Hook spanner (HCP 040-150)	503418

EHC Electrical Pump Unit

Order No. 503708

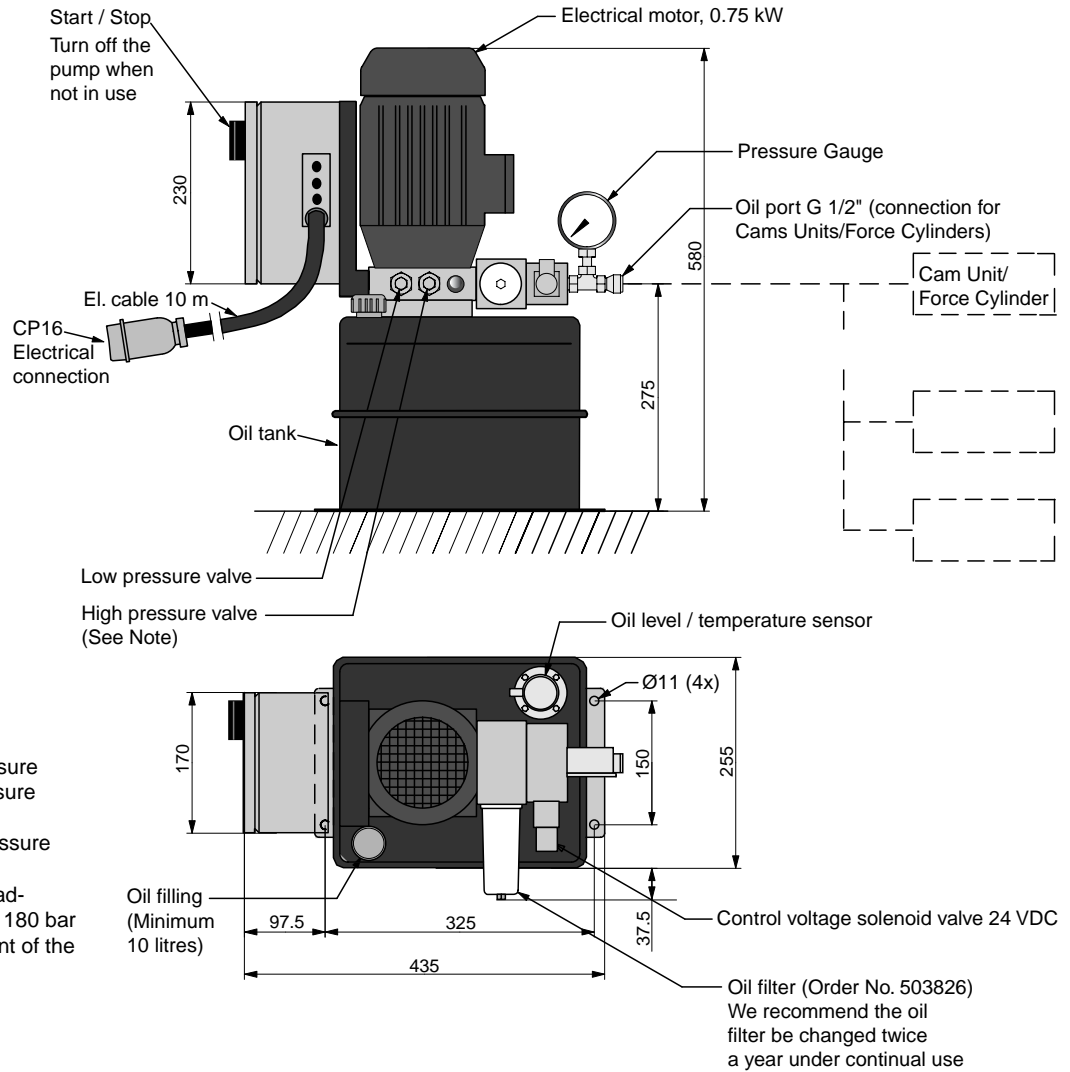

Note!
Both the Low and High Pressure valves have adjustable pressure settings.
We recommend the Low pressure valve is set to 25 bar.
The High Pressure Valve is adjustable up to a maximum of 180 bar depending on the requirement of the operation being performed

Technical data - hydraulic system	
Oil tank volume	15 l
Hydraulic oil ISO VG 32	DIN 51524 HVL P (or equivalent)
Min oil flow at 180 bar	1.6 l/min
Max oil flow at 25 bar	8.7 l/min
Oil pressure during cam travel	10-20 bar
Oil pressure during cam operation	Max 180 bar
Low and High pressure valves	(See Note)

Technical data - electrical system	
Main voltage electrical pump	3x220-440 VAC 50-60Hz
Control voltage solenoid valve	24 VDC
Overtemp sensor max oil temp.	70+5°C
Overtemp sensor restart temp.	50°C

Cam Unit/Force Cylinder size	Cam Unit/Force Cylinder velocity*	
	Forward + return	During operation
	(Low pressure)	(High pressure)
015	115 mm/s	21 mm/s
040	47 mm/s	9 mm/s
060	29 mm/s	5 mm/s
090	18 mm/s	3 mm/s
150	12 mm/s	2 mm/s

*The table shows approximate values based on a single Cam Unit/ Force Cylinder connected to a single EHC Electrical Pump Unit. When using more Cam Units/Force Cylinders connected to one EHC Unit divide the velocity by the number of Cam Units/ Force Cylinders. Ex: 115/3 Cam Units/Force Cylinders = 38 mm/s

**Cam Units/Force Cylinders forward:
Activated by the control signal (24 VDC)

**Cam Units/Force Cylinders return:
Activated by the inbuilt gas return in the Cam Unit/Force Cylinder

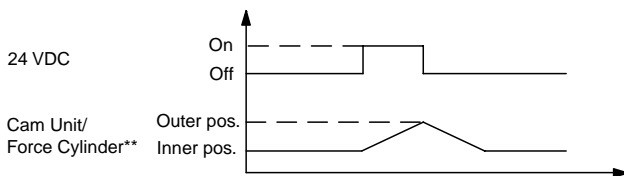

Installation and Service

Safety guidelines

Symbol to observe



This symbol means that special attention is required.

Personnel

All personnel whom operate or maintain this equipment must fully understand how it works. Always wash your hands after working with hydraulic systems.

Work place

The work place must be kept absolutely clean during installation or maintenance of the Flex Cam.

Equipment

Use only clean and functional tools and proper protection for your eyes and skin.

Adapters for hoses

Upon delivery, all connections on the units are plugged. To reduce the risk of contamination from foreign bodies, remove the plugs only when absolutely necessary.

Nitrogen products

Be very careful when working with nitrogen products. See special instructions for gas springs, because wrong handling could cause personal injury. Make sure that there is enough room for the Accumulator in the tool.

Hoses

The hoses are washed and plugged to protect them from dirt as this could damage the system. Make sure that the hoses are protected against sharp edges and external damage. The hoses will move a little depending on the oil pressure pulsation during operation.

Torque settings for screws

Always use a torque wrench when tightening screws. See Table 1 which is valid for oiled screws of 12.9 quality.

Screw dim	Allen key	Torque (Nm)
M 6	5	15
M 8	6	40
M 10	8	75
M 12	10	135
M 16	14	330
M 20	17	640

Table 1

Installation

The following information describes only the most important recommendations. If there are any questions about the installation do not hesitate to contact your local distributor or Strömsholmen AB.

Tel +46 140-571 00

Fax +46 140-571 98

Web site: www.kaller.com

Power Unit

The Power Unit can be mounted in any position in the tool, including upside-down (valid for all units). A driver (1) is often used and adapted to give the right stroke length of the Power Cylinder.

 **Make sure the surface which makes contact with the piston on the top of the Power Cylinder is parallel and even. Make sure there is enough room for the Accumulator in the tool.**

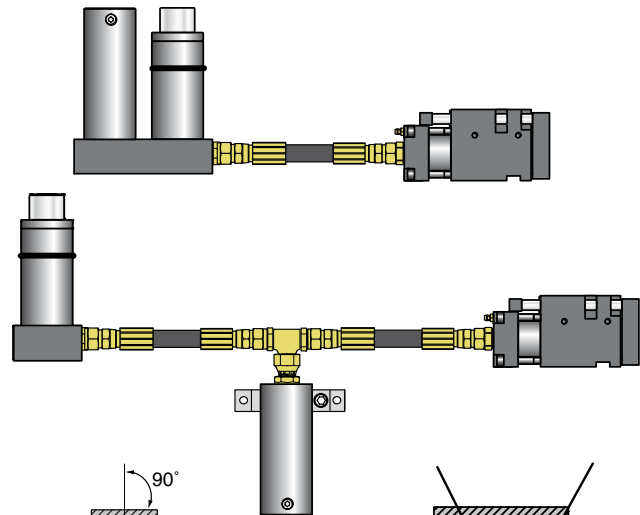
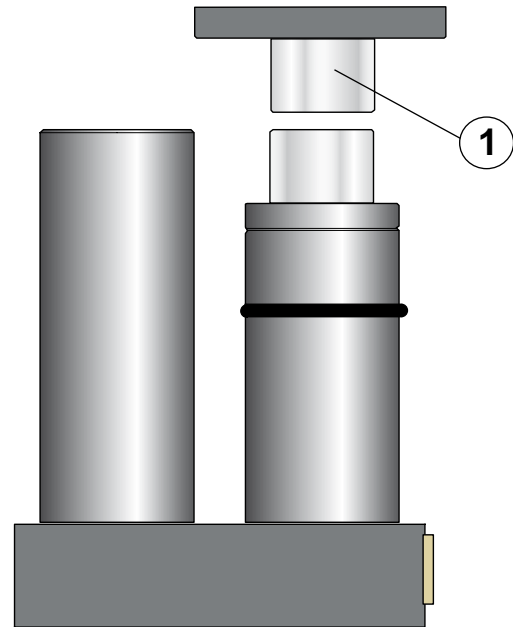

Power Unit Mounting Instructions (HCP, HCP-S)

Mount the Power Unit to a flat surface using four screws, either upright or upside down. To ensure the Cam Unit/Force Cylinder always travels the same stroke length it is customary to stroke the Power Unit an extra 10 mm, which also causes the Accumulator's piston to rise ca. 10 mm.

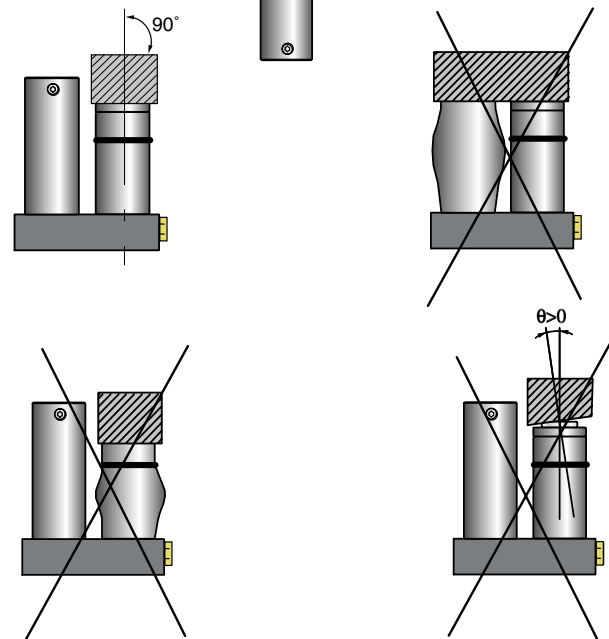

Compact Cam

Use dowel pins and a key to locate the position of the Cam Unit in the tool.

The punch plate (1) can be removed for machining by first removing all three screws (2) from the plate.

The reaction force, created as a result of the forming/piercing operation being performed by the Cam Unit, can be located within any part of the shaded area (3).

However, it is recommended to position this force directly in the centre of the shaded area (3). For more information, see the respective Cam Unit dimensions page.

Please note, it is not recommended to put any turning moment on the punch plate (1).

When mounting a punch directly onto the punch plate (1), or via a ball lock punch retainer, the gas spring (4) should be in place before any final adjustments are made.

Use the Pump Unit (see page 9.8/44) together with a thin metal plate or thick piece of paper to check the punch is positioned correctly.

For Installation Examples, please see page 9.4/1.

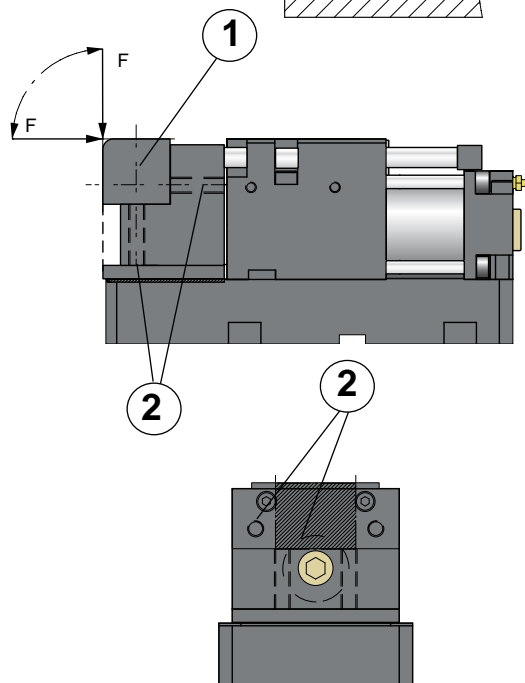
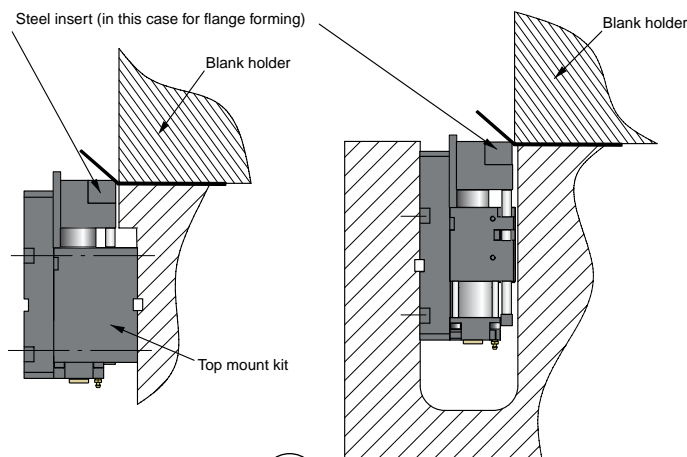
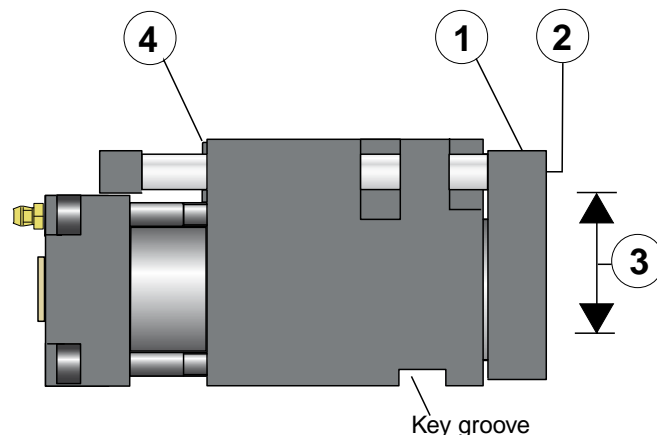

Flange Cam installation possibilities

The Flange Cam can be mounted at any position in the die.

For the top mount, a "top mount kit" is needed but not for the base mount.

Flange Cam force direction and location

The customised tool (1) (for flanging etc.) should be mounted using two or four bolts (2) within the designated area.

The force created by the flanging is allowed in directions "F" within the area marked .

Force Cylinder

Use only flanges or fittings intended for the Force Cylinder. See also page 9.7/1 for "Technical data". The threaded holes at the top of the piston rod can be used to mount the fitting for the tool in a pushing- and pulling application. Note that it is not possible to load any force in an off centre position or as a side load.

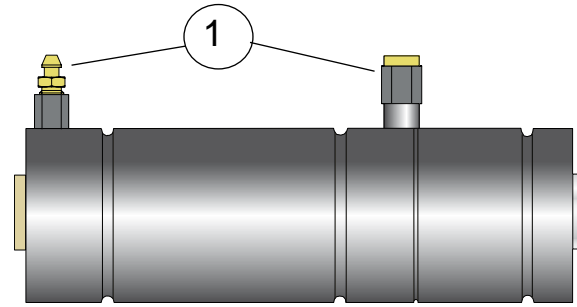

Make sure there is enough room to fill and bleed the force cylinder in the die (1).

See also page 9.8/42-43.

Hydraulic hose and adapters



See page 9.8/27 to choose the adapters and the hose. Use as few adapters as possible and note that the hose is available with an elbow fitting.

The hoses are washed and plugged to protect them from dust as this could damage the system. Make sure the hoses are protected from sharp edges and external damage. Sharp edges must be rounded (1). Hoses will move a little depending on the oil pressure pulsation during the operations. Do not use a smaller bending radius than specified (2).

Adapters for the units have an O-ring (3) and a support washer (4) which must always be used. Check also that no movable parts can touch the units or the hoses. See also DIN 20066 for hose installations.

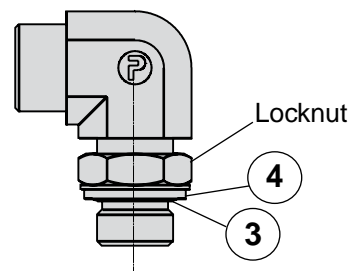
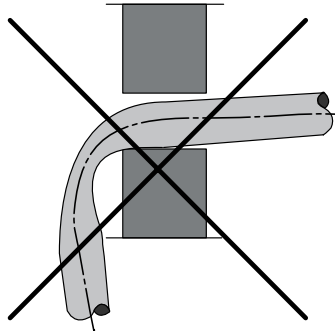
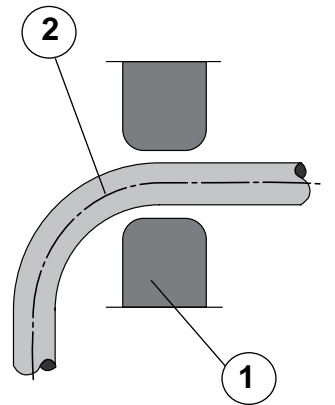

Filling of gas and oil

Gas charging for / Force Cylinder and Accumulator

Equipment needed:

Nitrogen bottle with at least 180 bar

Charging armature P/N 3015075-2000

Allen key 5 mm

Step 1 Connect the nitrogen bottle

Connect the Charging armature to the nitrogen bottle which should have at least 180 bar pressure.

Step 2 Gas charging of the Force Cylinder (Not valid for Compact Cam)

Turn the small knob (1) anticlockwise until the release pin is inside the thread. Connect the adapter (2) to the armature. Remove the plug on the Force Cylinder and connect the armature by turning knob (3) clockwise. Open the gas valve carefully anticlockwise using knob (4). Charge gas until the manometer (5) shows 20 bar (max 40 bar).

To empty, open knob (6) and the gas valve of the Force Cylinder by carefully turning knob (1) clockwise.

Remove the armature and fit the plug.

Step 3 Charging of gas in the Compact Cam CC-H.

If the Compact Cam is connected to a hose system the filling pressure is:

CC 015	180 bar
CC 040	180 bar
CC 060	180 bar
CC 090	150 bar
CC 150	150 bar

If there is no hose system then, gas charging is not required.

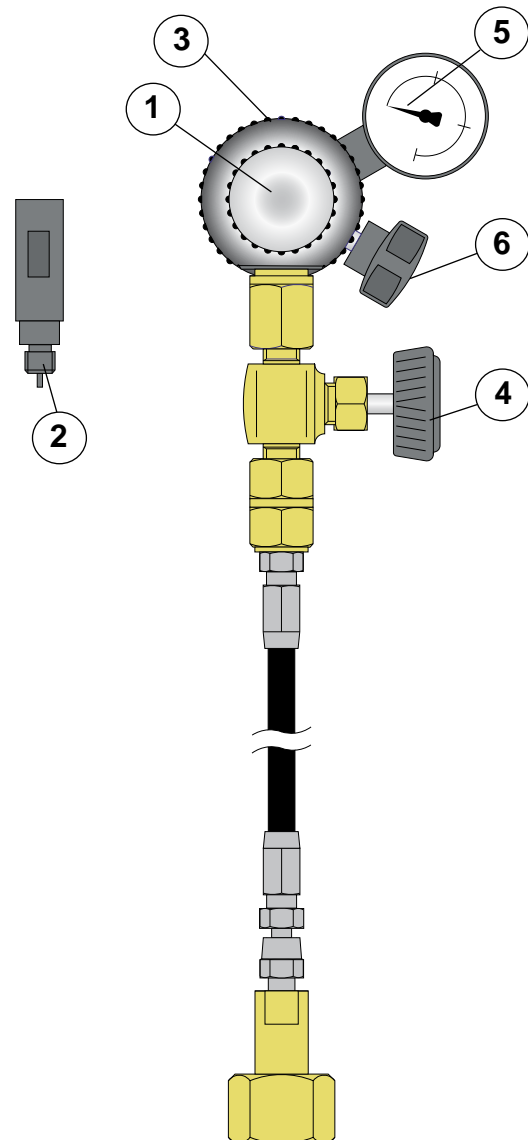

Step 4 Charging of gas in the Accumulator

! Charge the Accumulator with 25 bar as per the procedure above. The Accumulator must be charged with 150 bar or to a pressure suitable for the operation after the oil filling procedure. See also page 9.7/1.

It is possible to change the gas port location (1) by first emptying the gas pressure then twisting the accumulator tube to position (2).

When not using the charging armature empty the gas by closing the nitrogen bottle valve and opening the gas valve (4) anticlockwise. (See page 9.11/1)

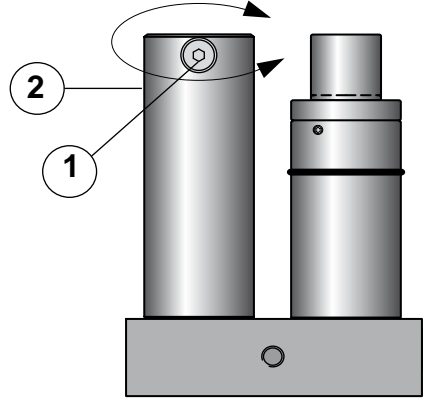

Oil filling and bleeding

Equipment	Size	Order. no
Pump Unit		30 170 75
Hook spanner (-015)	3 mm	503 417
Hook spanner(-040-150)	5 mm	503 418
Allen key	6 mm	
Open-ended spanner	11 mm	
Open-ended spanner	14 mm	
18 litres of oil as per specification on page 9.7/1.		

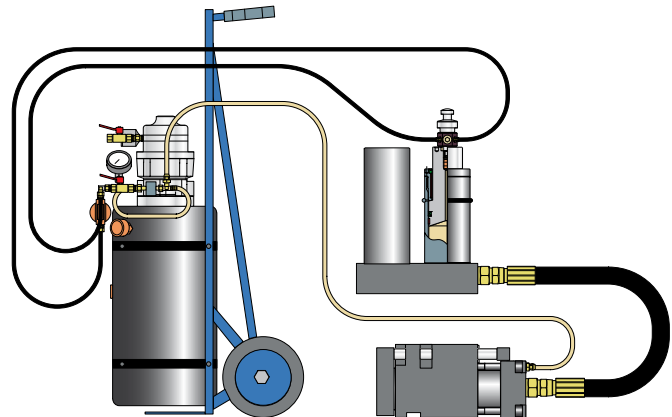

Compressed air information

Pressure between 5-7 bars.

Moisture trap, filter and automatic air line lubricator must be installed in the air line to feed the air motor of the pump.

Step 1 Check the nitrogen pressure

! Charge the Cam Unit/Force Cylinder and Accumulator according to this table. Make sure that the area around the units is kept clean and dry.

Cam Unit/ Force Cylinder					Accumulator	
CC-H					HCF	HCP
015	040	060	090	150		
180 bar			150 bar		20 bar	25 bar

Step 2 Connect the Pump Unit

Turn knob (1) anticlockwise until the release pin for the valve (2) is inside the thread. Remove the plug and connect the oil armature on the top of the piston (3) by turning knob (4) clockwise. Open the valve (2) by turning knob (1) clockwise carefully until the stop is reached. Connect the transparent hose between the bleed nipple (5) and the Pump Unit (6). Connect compressed air to the valve (7) (thread G 1/4").

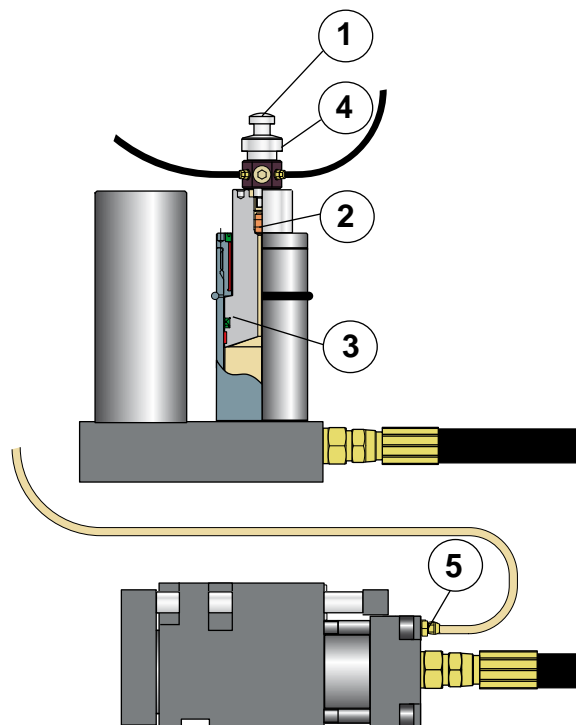

Step 3 Check the clearance of the Cam Unit/ Force Cylinder

⚠ Check the clearance of the Cam Unit/ Force Cylinder and make sure that there is enough room for a full stroke.

Step 4 Pump oil

Open the bleed nipple (5) and close the valve (9). Pump the oil by opening valve (7) until the oil is free from air bubbles. Close the bleed valve (5).

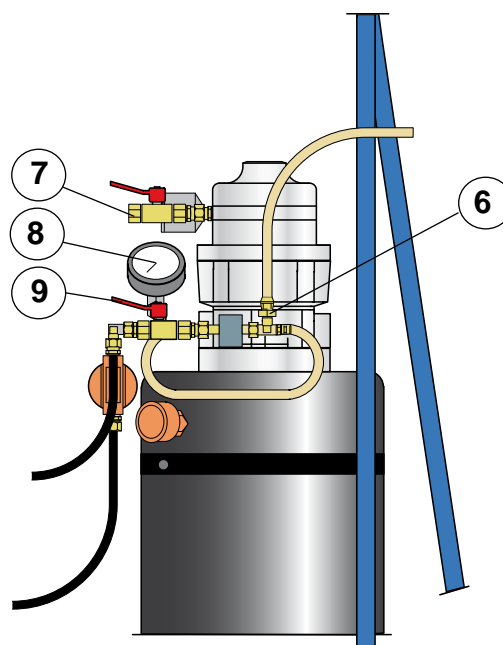

Step 5 Bleeding the Cam Unit/ Force Cylinder

Pump oil until 50 bar oil pressure (8), open bleed nipple (5) and bleed the Cam Unit/ Force Cylinder. Have a cloth at the ready to collect any oil that may leak out. Note that the Cam Unit/ Force Cylinder will move the full stroke. Close the bleed nipple (5). Repeat this until the oil is free from air bubbles.

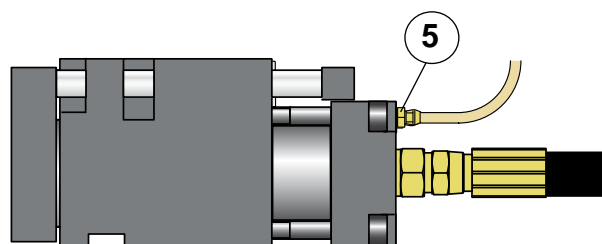

Step 6 Bleeding the Power Unit

Pump until the oil pressure is 50 bar, open the valve (9) and bleed the Power Unit. Close the valve (9). Repeat this until the oil is free from air bubbles.

Step 7 Check that the oil is free from air

! First make sure that the oil pressure is 0 bar, ie. pressureless. Try to push the piston down by hand. If it is possible to push it down a little there is some air left in the system. Repeat step 5 and 6 until the oil is totally free from air or the piston can not be moved.

Step 8 Check for any leakage

! Pump until oil pressure is 50 bar and look for any leakage from the adapters and the units. Make sure that the oil pressure is 0 bar by opening the bleed valve (9).

Step 9 Disconnect the Pump Unit

Uncouple the oil filling armature and the transparent hose. Fit the plug on the top of the Power Cylinder by using the hook spanner to hold the piston. Tighten the bleed valve on the Cam Unit/ Force Cylinder and clean the area.

Step 10 Charge the Accumulator with Nitrogen

After the oil filling procedure, the Accumulator has to be charged with nitrogen up to 150 bar or to the required gas pressure for the operation. Maximum pressure is 180 bar. See also page 9.7/2.

The system is now ready for operation.

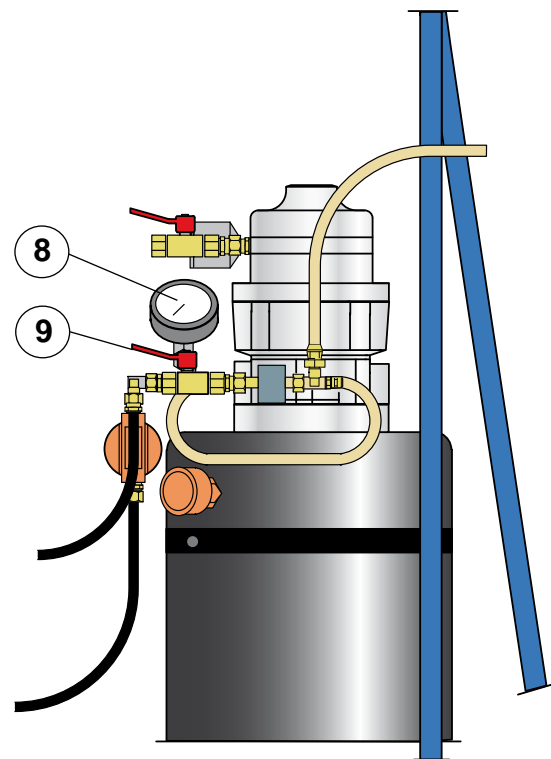

Changing the oil

Follow step 1 to 11 as before but connect the transparent hose to a reservoir for used oil, not to the pump unit. Pump oil until new oil comes out through the transparent hose.

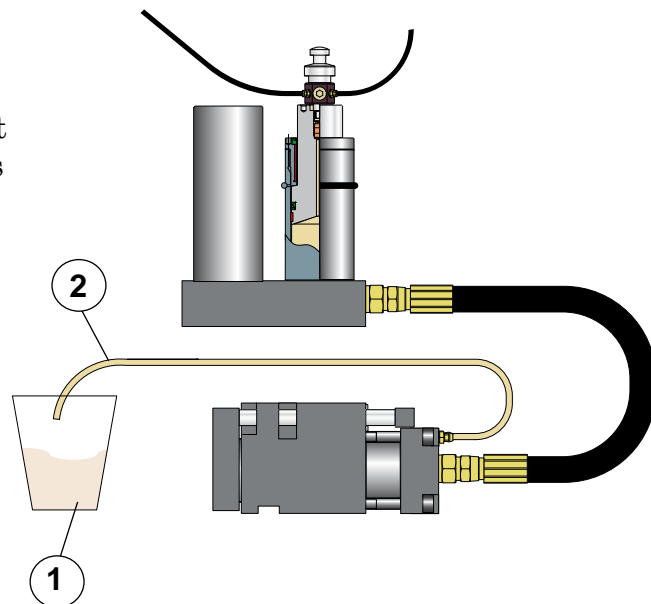

Service and maintenance



The life time of the products is normally 1 million operations provided the installation and maintenance is performed correctly. In special conditions or environments the life time may be shorter or longer.

Power Unit and Force Cylinder (HCP, HCP-S, HCF)

Check the nitrogen pressure in the Accumulator and the Force Cylinder every 200'000 strokes or alternatively twice a year.

See also page 9.7/1 and 9.11/1.

Compact Cam (CC)/ Flange Cam (CCF)

Check the force of the return springs every 200'000 strokes or twice a year by removing the screws (1) and the spacer (2). Pull out the gas springs and use a test rig to measure the force of the gas springs.

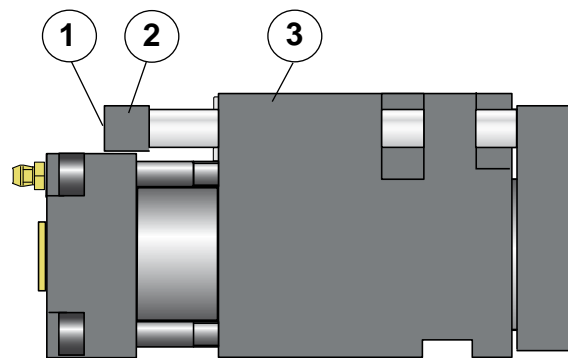

The table below shows the type of gas springs and force for each Cam Unit

Cam Unit	Gas spring for return	Gas spring force	Min gas spring force*
CC 015	1 X M2 200 - stroke	200 daN	140 daN
CC 040	2 X M2 200 - stroke	200 daN	140 daN
CCF 040	2 X M2 200 - stroke	200 daN	140 daN
CC 060	2 X X 350 - stroke*	350 daN	250 daN
CC 090	2 X TU 500 - stroke*	500 daN	350 daN
CC 150	2 X X 750 - stroke*	750 daN	530 daN

* If the gas spring force is lower than minimum the gas spring has to be replaced

Compact Cam (CC-H) and Flange Cam (CCF-H) for Hose Systems

Check the nitrogen pressure in the Compact Cam every 200'000 strokes or twice a year.

See also page 9.11/1.

When changing the gas spring, do not allow the oil within the spring to escape.

The table below shows the type of gas springs used for each cam unit.

Cam Unit	Gas spring for return	Gas spring pressure	Min gas spring pressure**
CC-H 015	1 x MH 200 - stroke	180 bar	125 bar
CC-H 040	2 x MH 200 - stroke	180 bar	125 bar
CCF-H 040	2 x MH 200 - stroke	180 bar	125 bar
CC-H 060	2 x X 350 - stroke*	180 bar	125 bar
CC-H 090	2 x TU 500 - stroke*	150 bar	105 bar
CC-H 150	2 x X 750 - stroke*	150 bar	105 bar

* Be sure to remove the nitrogen charging valve in the springs when connecting to a hose system. The MH has no valve.

** If the pressure is lower than minimum check the hose system and if necessary change the gas springs.=

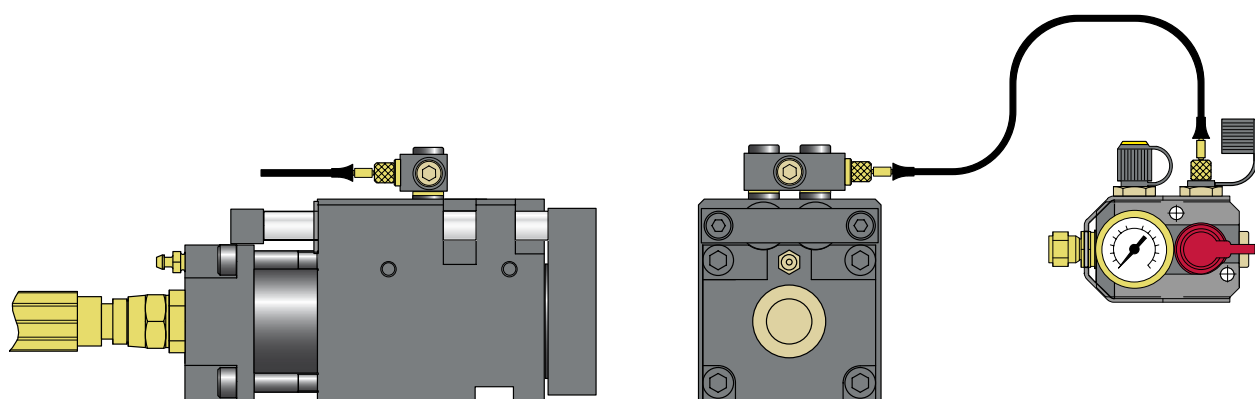

Oil

It is recommended to change the oil after a running-in time of approximately 100-1000 operations. After that the oil is recommended to be changed after 500'000 operations or every two years. When changing the oil, the old oil must be pumped out from the system. See also page 9.7/1 and 9.11/5.

Pump Unit

Change the filter (1) and the transparent hose (2) every 200 working hours or every two years. Remove the complete filter by loosening the adapter and the hose. Put the filter in a vice and remove the bottom by turning it anticlockwise. Replace the filter and put the new filter in position together with the washer.

Filter Order No.: 503 419

Transparent hose Order No.: 503 116

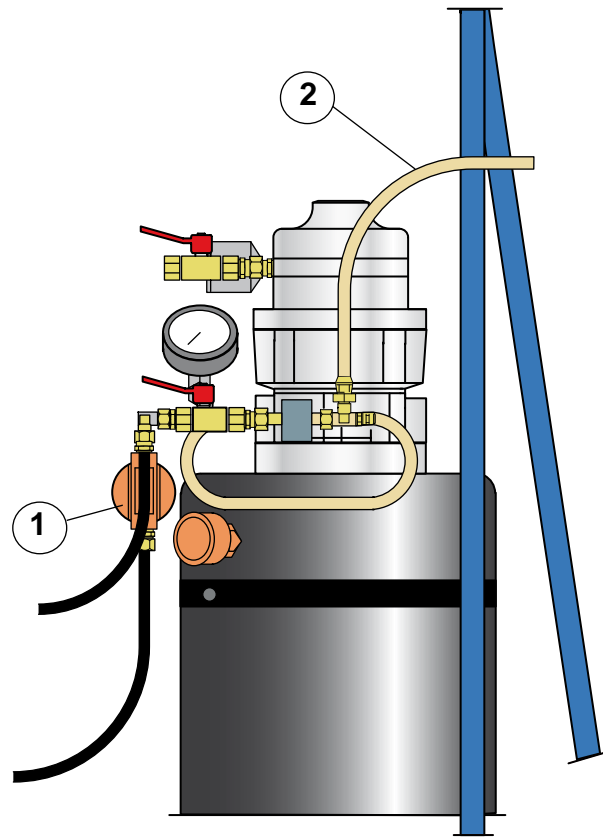

Service



This high precision equipment containing high pressure nitrogen must only be maintained or serviced by authorised fully qualified personnel. For any advice about this equipment contact your local Kaller distributor.

Fault diagnosis and solutions

Description of fault	Possible cause	Measure taken
1. Cam Unit/Force Cylinder does not perform a full stroke.	1:1 Low gas pressure in the Accumulator	Charge up the gas pressure, see page 9.11/1. (max 180 bar)
	1:2 Power Cylinder does not perform a full stroke	Adjust the stroke length
	1:3 Oil leakage in Power Cylinder A: The port plug has come loose B: Damage on the seal and/or inside of the Power Cylinder	A: Replace the plug and fill the system, see page 9.11/1 B: Contact your distributor for service or replacement cylinder
	1:4 Oil leakage in Cam Unit A: The bleeding valve has come loose B: Damage on the seal and/or inside of the Cam Unit	A: Replace the bleed valve and fill the system, see page 9.11/1. B: Contact your distributor for service or replacement Cam Unit
	1:5 Hose or adapter has come loose or been damaged.	Replace the defective parts and fill the system, see page 9.11/1.

Description of fault	Possible cause	Measure taken
2. Cam Unit/ Force Cylinder does not retract.	2:1 Low gas pressure in the Force Cylinder (the Force Cylinder has to be in retracted position)	Check if the gas adapter or the plug have become loose. Charge with gas, see page 9.11/1, max 40 bar. If the gas quickly leaks out again, contact your distributor for service or replacement Force Cylinder.
	2:2 Low gas pressure in the return springs of the Compact Cam.	Replace the gas springs, see page 9.12/1. If hose system is used, check and see page 9.12/2.
	2:3 Gas leakage in the Accumulator	Bleed the oil, see page 9.11/2. Contact your distributor for service or replacement Accumulator.
	2:4 The return movement is jammed.	Contact your distributor for service or replacement Cam Unit/ Force Cylinder.



The Safer Choice

1 ABOUT THE COMPANY

2 GAS SPRINGS INCLUDING STANDARD MOUNTS

3 SPECIAL MOUNTS

4 HOSE SYSTEM

5 NITRO SUSPENSION SYSTEMS

6 COUNTERBALANCE SYSTEMS

7 SPECIAL APPLICATIONS

8 SERVICE AND MAINTENANCE

9 PIERCING AND FORMING UNITS / CAMS

10 CONTROLLABLE GAS SPRINGS



For more information see our website

www.kaller.com